

## **9.1 Introduction**

Corrugated high-density polyethylene and polypropylene pipes, herein called Corrugated Polyolefin Pipe (CPP), are ideal for use in a wide range of buried applications. This chapter discusses proper techniques for CPP installations, which includes unloading through final backfilling. Each step of the process is described for standard drainage installations so that the engineer or contractor can be confident of achieving a sound installation that will last for the intended design life.

Many of the recommendations in this chapter are based on the ASTM D2321 “Standard Practice for Underground Installation of Thermoplastic Pipe for Sewers and Other Gravity-Flow Applications” (1). In this chapter, small pipes are defined as those having diameters up to and including 18 in. (45 cm), while large pipes have greater than 8 in. (45 cm) diameters. The PPI member companies have used these procedures successfully in a variety of situations for several decades.

Information is also included that covers unique applications and special situations. CPP is versatile and can sometimes be used in ways that other pipe materials could not, such as in more specialized installations.

## **9.2 Unloading, Handling and Site Storage**

This section addresses proper receiving, handling, and site storage of the pipe to preserve its original integrity. These activities are important first steps in producing a reliable installation.

### **9.2.1 Inspection**

Once the pipe is received on the job site and prior to final acceptance, an inspection should be completed to ensure all products are correct, accounted for, and undamaged. The shipment should be compared with project requirements. CPP should be marked with the product name and/or manufacturer, nominal size, and applicable specification(s).

### **9.2.2 Unloading and Storing**

Prior to unloading the pipe, a designated area on the jobsite should be reserved for the storage of pipe materials. The area should be flat and free of debris and hazards, including large rocks, construction material, and harmful chemicals. The storage area should also be located far enough away from construction traffic in order to avoid potential contact.

CPP is shipped in a variety of forms (i.e., coils, individual lengths (sticks), bundled lengths, and palletized lengths) and unloading methods will vary. Light compact pieces can be moved by hand but generally this applies for 18-in. (45-cm) diameter and smaller pipe sizes. However, heavy or bulky CPP including large coils of single wall pipe generally require equipment, such as a forklift, loader, backhoe, or crane. If a sling or cable is used, it should be attached to the pipe in a manner that minimizes bending. Coiled pipe can be unloaded using equipment with a sling or strap looped through the center of the coil. Individual lengths of loose pipe can be unloaded by carefully rolling the pipe onto a forklift or loader and then lowering the pipe to the ground. Alternatively, a nylon sling or cable can be used to lift at the one-third points as shown in Figure 9.1.

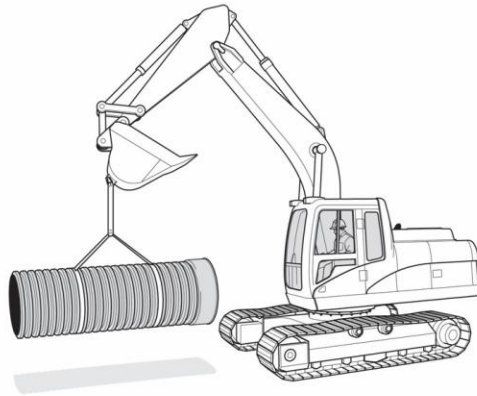

**Figure 9.1: Lifting Larger Diameter Pipe**

In order to avoid damage to CPP, bare chains or metal cables should not be used. Single sticks of small pipe can be carried by hand as shown in Figure 9.2, while taking care to avoid dragging the pipe ends. Bundled lengths will require equipment and a sling or strap at the one-third points of the bundle. Palletized pipe can be unloaded using a forklift or other equipment in combination with a sling or cable wrapped around the pallet. Manufacturers may provide additional unloading guidance specific to the products and packaging methods used on a particular shipment.

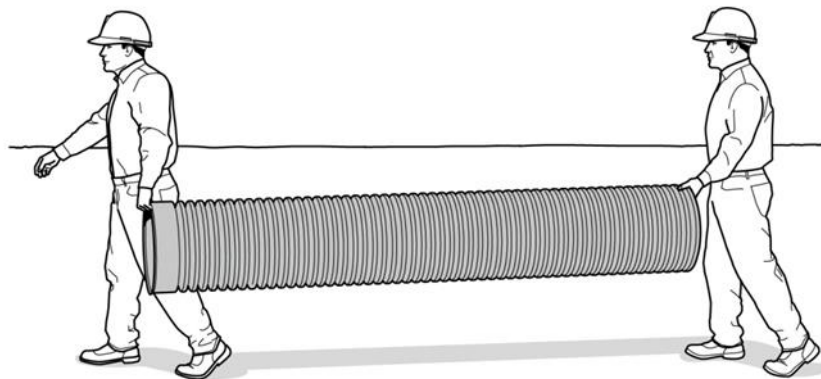

**Figure 9.2: Lifting Small Diameter Pipe**

Once the products are unloaded, they should be placed in the storage area until installation. Coiled pipe can be placed on its side. Pipe that is bundled or palletized can be left intact until it will be installed, but they should not be stacked. Individual lengths of pipe can be carefully stacked. One stacking method commonly used is to secure the bottom lengths of pipe together side-by-side, or use stop blocks, and then place additional pipe on top. When pipe is stockpiled, the pipe must be adequately restrained to prevent pile collapse or rolling of the pipe stockpile. It is not advisable to walk on stockpiled pipe. Pipe that is equipped with bell ends should be stacked in alternating directions in order to reduce the possibility of bell deformation as shown in Figure 9.3.

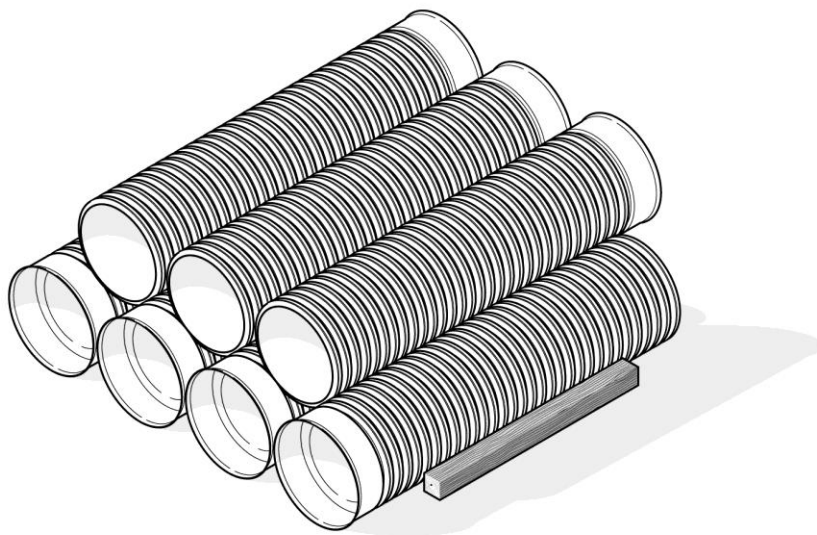

**Figure 9.3: Proper Stacking Alignment**

Pipe with factory-installed gaskets should be positioned such that the gaskets are placed between the corrugations on the adjacent pipe. Additional fittings, gaskets, and other accessories should be stored in a safe and convenient location and couplers and fittings should be stored in a manner that prevents distortion and damage.

Ambient temperature extremes do not affect the strength or handling characteristics of CPP. Cold temperatures can affect the impact resistance of some thermoplastics, although polyethylene remains highly impact resistant. Hot weather will raise the pipe temperature, especially when coupled with direct sunlight, but it will not significantly affect the handling or installation behavior of the pipe.

Depending on the pipe product, and the particular AASHTO or ASTM specification it meets, either carbon black or another UV stabilizer is added to the CPP to protect against UV light degradation. Such additives ensure that the pipe maintains its impact resistance during storage periods at the manufacturing facility and at the job site. When gaskets are installed on the pipe, a protective covering should be in place in order to limit environmental exposure. If gaskets are not covered, they should be stored in a protected location and placed on the pipe prior to installation. Ultraviolet light is no longer an issue after the pipe is installed.

“Stringing” or laying out the pipe along the proposed trench line is a commonly-used practice, and it allows the pipe to be picked up and installed in one operation. The pipe should be strung out in a way that does not interfere with the excavation process. The pipe should be transported from the site storage area to the proposed trench using an appropriate method as previously described. Blocks and supports should be used to prevent the pipe from rolling or deforming.

### 9.3 Pipe Joint Assembly

Before pipe is laid into the trench, it should be reinspected for any damage and any debris that may have accumulated on the inside of the pipe, the gaskets, or sealing surfaces should be cleaned as in Figure 9.4. The pipe should also be checked to ensure that it is the correct type and size.

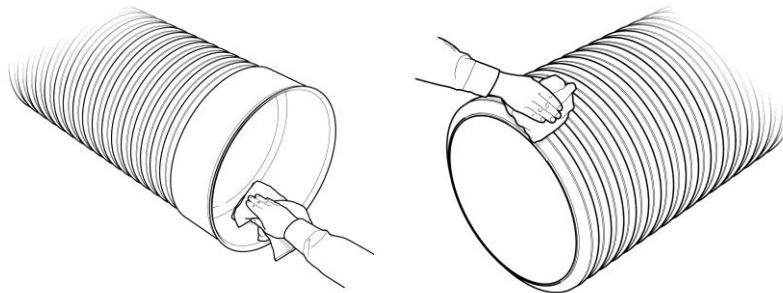

**Figure 9.4: Cleaning Seal Surfaces of Pipe**

The pipe should be lowered into the trench using slings placed in a manner that evenly supports the pipe. It is good practice to use a tag line (i.e., a line attached to the end of the pipe that prevents uncontrolled pipe movement) when positioning the pipe. Pipe equipped with integral bell and spigots must be installed by inserting the spigot into the bell as shown in Figure 9.5.

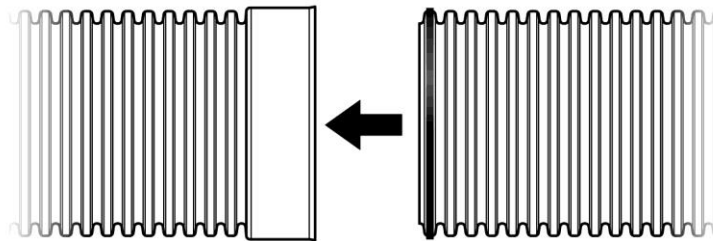

**Figure 9.5: Integral Bell and Spigot Connection**

The action of pushing the bell onto a spigot increases the likelihood of forcing bedding material into the joint, disrupting the gasket and undermining the pipes watertight performance. As such, pipe laying should begin at the lowest point of the project with spigots pointed in the down-grade direction. When the spigot is ready to be inserted into the bell, the protective film around the gasket should be removed. A clean brush, cloth rag, sponge or gloved hand should be used to apply an approved pipe lubricant to both the gasket and the bell. Alternatively, aerosol lubricant products approved by the manufacturer may be used. It is essential to not allow the lubricated section of pipe come into to contact with dirt or backfill material. Foreign matter could adhere to the lubricated surface and then compromise the integrity of the joint. The failure to properly lubricate the joint can adversely affect the joint performance and will increase the force needed to secure the joint.

There are a few ways to push the pipe together. Smaller diameter pipe may be pushed together by hand or leveraged together using a spanner block and a lever as shown in Figure 9.6.

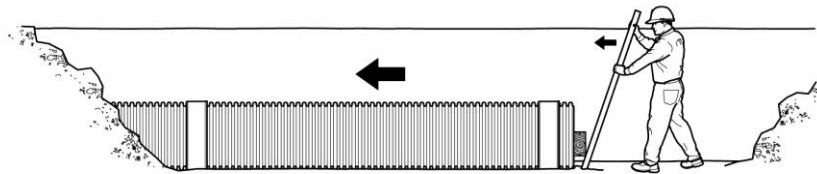

**Figure 9.6: Installing Small Diameter Pipe**

Larger diameter pipe typically requires more force to assemble and typically necessitates the use of machinery, such as a backhoe. One method of using a backhoe for assembly is to use the slinging strap to position the spigot into the bell of a previously-installed pipe, as shown in Figure 9.7. A pipe is properly joined when it is pushed together in a straight alignment.

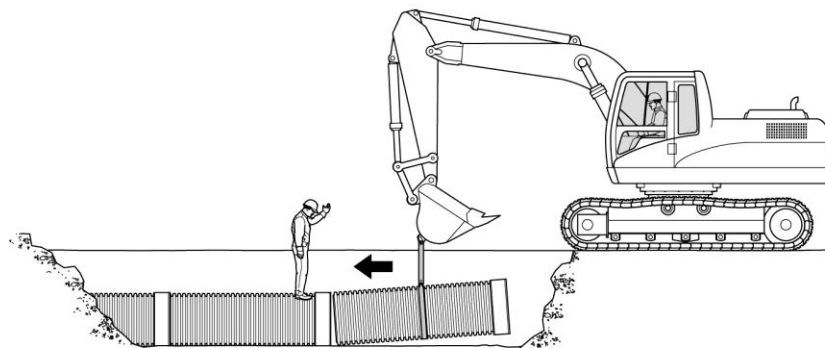

**Figure 9.7: Installing Large Diameter Pipe with Sling**

Another method involves pushing the pipe joints together. For this method, a sacrificial spigot or portion of pipe of the same size is placed inside the bell of the pipe to be installed, and then the assembly is pushed into the bell of a previously-installed pipe, as shown in Figure 9.8.

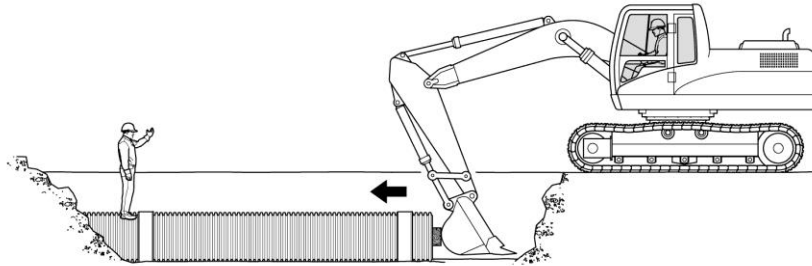

**Figure 9.8: Installing Large Diameter Pipe with Stub**

This sacrificial installation stub acts as a bumper to prevent damage to the pipe from the bucket. When using machinery to assemble joints, caution should be used to assure that the pipe joints do not slam together and that the pipe already installed is not shoved out of alignment (i.e., over-homed). A spotter should observe the spigot insertion and should signal to the operator when the joint is completely inserted which can prevent an over-homing condition.

Regardless of the jointing method used, it is very important to maintain both horizontal and vertical pipe alignment. Improper alignment will result in difficult or improper joint assembly and may compromise the pipe's joint integrity.

## **9.4 Overview of Installation Considerations**

This section provides recommended trench construction, pipe installation, backfill selection and placement, as well as specialized installation considerations for CPP. However, defining the terminology used in this chapter is critical to the understanding of proper installation.

### 9.4.1 Trench and Soil Terminology

The basic terms that relate to trench installation and pipes are illustrated in Figure 9.9 and are listed as follows:

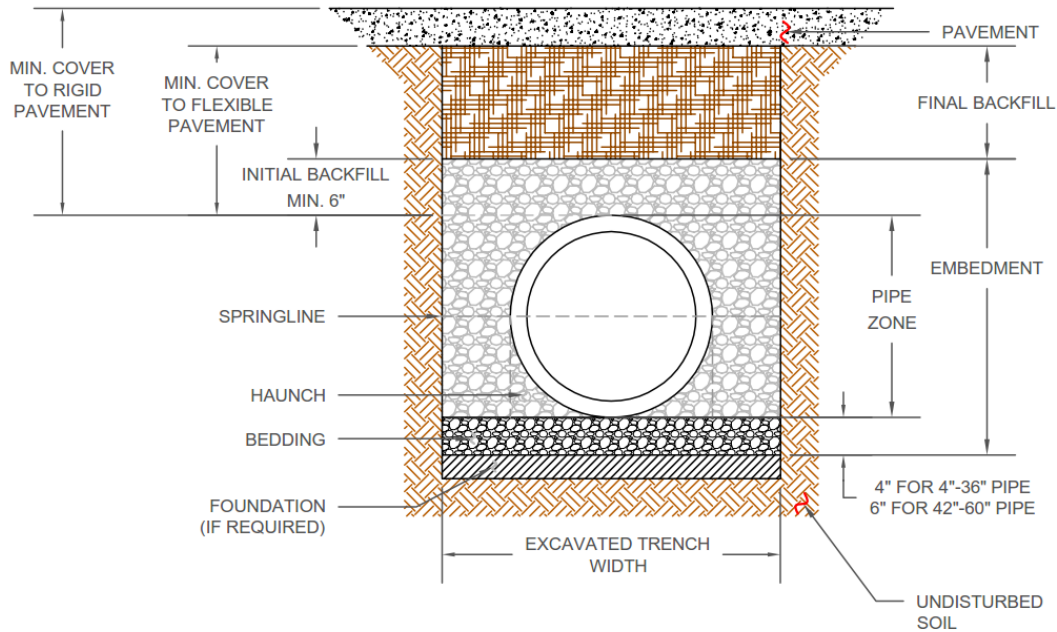

**Figure 9.9: Typical Trench Installation (2)**

**Bedding:** the bedding is the soil placed in the bottom of the trench on top of the foundation;

**Embedment:** the embedment includes the bedding, the pipe zone, and the initial backfill;

**Final Backfill:** the final backfill is the soil placed over the initial backfill up to the final ground surface;

**Foundation:** the foundation is the native soil in the bottom of the excavation. If the native soil is unsuitable, a replaced foundation will be necessary;

**Haunch:** the haunch is the triangular area below the pipe that extends from the springline to the bottom of the pipe;

**Initial Backfill:** the initial backfill extends from the top of the pipe to a minimum of 6 in. (15 cm) over the top of the pipe;

**Pipe Zone:** the pipe zone is the area of soil support on the sides of the pipe;

**Springline:** the horizontal centerline of the pipe is known as the springline; and,

**Trench Walls:** the trench walls are the native soils on the sides of the excavation.

The soils are referred to using the classifications from ASTM D2321 (1) and are shown in Table 9.1. ASTM D 2321 associates the classes of soils to be Class I with the highest inherent stiffness through Class V that has the lowest stiffness. At the same level of compaction, Class I soils provide the greatest amount of stiffness for the pipe while Class V provides the least amount of support. Higher stiffness soils provide a greater amount of support for the pipe, which ultimately enables the pipe to be installed in more structurally-demanding applications. For the pipe embedment, Class I, II, and III soils are recommended. The pipe manufacturer and/or a geotechnical engineer should be consulted for exceptions to these suggested soils.

Table 9.1 lists the soil groups in descending order of stiffness and provides both a general description of the soil and a more precise description with reference to the Unified Soil Classification System (USCS) as described in ASTM D2487 (3).

**Table 9.1: Soil Groups**

<b>ASTM D2321 Classification</b>	<b>General Description</b>	<b>USCS ASTM D2487 Description</b>	<b>Specific Description</b>
Class I	Crushed Rock	GP <sup>1</sup>	100% passing 1-1/2-in sieve, ≤ 25% passing 3/8-in sieve, ≤ 15% passing #4 sieve, ≤ 12% passing #200 sieve
Class II <sup>2</sup>	Clean, coarse grained soils	GW, GP, SW, SP (SP - uniform fine sands - with more than 50% passing a #100 sieve should be treated as Class III material)	Or, any soil beginning with one of these USCS symbol (can contain fines up to 12%)
Class III	coarse grained soils with fines	GM, GC, SM, SC	or any soil beginning with one of these USCS symbols
	sandy or gravelly fine-grained soils	ML, CL (with ≥ 30% retained on #200 sieve)	or any soil beginning with one of these USCS symbols
Class IV	fine-grained soils	ML, CL (with < 30% retained on #200 sieve)	or any soil beginning with one of these USCS symbols
Class V	fine-grained soils, organic soils	MH, CH, OL, OH, Pt	high compressibility silts and clays, organic soil



Notes:

1. For Class I, particle faces shall be fractured. Technically GP refers to naturally occurring poorly graded gravel. However, ASTM D 2487 allows classification of processed or manufactured soils meeting this description. When processed or manufactured materials are intended, the symbol is enclosed in quotes (i.e. “GP”). For the purposes of this Handbook, naturally occurring and processed poorly graded gravel will be referred to as GP.
2. Materials such as shells, slag and recycled concrete (with less than 12% passing a No. 200 sieve) should be treated as a Class II soil. However the strength and stiffness characteristics must be evaluated before use with CPP.

Structural backfill as used in this handbook refers to a compacted Class I, II, or III soil and specifically excludes Classes IV and V. Flowable fill is also considered a structural backfill and will be discussed later in this chapter.

### **9.4.2 Soil Compaction Terminology**

Soil densities are referenced throughout this handbook. The standard proctor density is used to describe the density of cohesive soils and the constrained modulus is a measure of soil stiffness. The soil stiffness increases with increasing levels of compaction of the soil and the pipe’s burial depth. The increased stiffness results from the additional compaction due to the pressure of the soil overburden and the higher confining pressures associated with the in-situ soils. Constrained modulus is used in the design of the CPP installation; therefore, obtaining the proper compaction is key to the soil stiffness and the corresponding pipe performance.

## **9.5 Trench Excavation**

Drainage projects usually require the pipe to be buried in a trench that has been excavated in undisturbed native soil. Although the trench geometry is established during design, the conditions found at the site can influence those requirements. Recommendations for trenches in most stable soils are provided and other factors that can affect those recommendations and procedures are presented.

### **9.5.1 Trench Width**

A stable native soil can simplify trench excavation and minimize unexpected conditions. A soil is usually considered to be stable if a person can walk over it without sinking or feeling the soil move beneath them. Most undisturbed native soils are considered to be stable due to many years of consolidation.

In a stable native soil, the trench width must only be wide enough to permit the adequate placement and compaction of the embedment materials around the pipe. Stable trench walls enhance the structural integrity of the system when the trench is relatively narrow; as a result, it is desirable to only disturb the amount of soil as necessary for the pipe installation. Trenches that are too narrow make it difficult to correctly place the backfill. Trenches that are too wide can take more time to construct and can require more backfill; however, they may not be as stable as the undisturbed native material.

Table 9.2 lists typical trench widths that work for situations involving stable native soils. The values create a trench that is wide enough to allow proper backfilling, while not detracting from the inherent quality of the native soil.

**Table 9.2: Typical Trench Widths**

Nominal Pipe Diameter, in (cm)	Trench Width, in (cm)
4 (10)	21 (53)
6 (15)	23 (58)
8 (20)	25 (63)
10 (25)	28 (71)
12 (30)	30 (76)
15 (38)	34 (86)
18 (45)	39 (99)
24 (60)	48 (122)
30 (75)	57 (145)
36 (91)	66 (167)
42 (106)	75 (190)
48 (122)	84 (213)
54 (137)	93 (236)
60 (150)	102 (259)

The values shown in Table 9.2 are for typical pipe diameters. Trench widths for actual diameters should be based on the following criteria:

- For nominal diameters of 10 in. (25 cm) and less, calculate trench width based on the pipe actual outside diameter plus 16 in. (40 cm); and,
- For nominal diameters of 12 in. (30 cm) and greater, calculate trench width based on the pipe nominal diameter multiplied by 1.5 plus 12 in. (30 cm).

This trench width criteria provides an adequate distance between the pipe and the trench wall in which to compact the initial backfill. Other special site or installation considerations may affect the trench widths given in Table 9.2. Poor site conditions, such as rock outcroppings or unstable soils, etc., cannot be ignored and thus these factors must be taken into consideration when designing the trench width.

As the trench is excavated, the sidewalls should remain reasonably vertical to the top of the pipe. For positive projection embankment installations, the embankment material should be placed and compacted to a minimum of 1 ft (0.3 m) above the target elevation for top of pipe, and the trench excavated into the embankment.

### 9.5.2 Shoring Using a Trench Shield

Shoring in a pipe installation usually involves a trench shield that protects workers from the possibility of soil collapsing on them while in the trench. These are used in deep installations, around unstable soils, in areas where a change in weather could quickly result in safety concerns, and any other situation where soil collapse is a possibility. An example of a trench shield or box is shown in Figure 9.10. These structures are placed around or above the pipe during installation and then moved along the trench as the installation proceeds. The length of the trench shield should be suitable for the pipe length. Pipe manufacturers may be able to provide different pipe lengths specific to the lengths of the trench shields available.

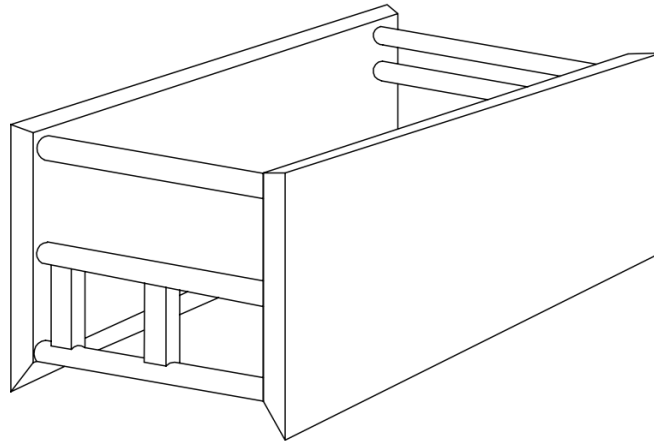

**Figure 9.10: Typical Trench Shield**

Some additional steps should be taken when using a trench shield so that both worker safety and a quality pipe installation are achieved. The most effective way to maintain a sound system when the shield will be located beneath the top of the pipe is to provide a subtrench as shown in Figure 9.11. The shoulders of the subtrench allow a place to rest the trench box, and the subtrench itself allows the pipe and backfill to be securely placed. OSHA specifies a maximum distance, of typically 24 in. (60 cm), between the bottom of the trench shield and the trench bottom, so that it can provide protection to workers. It is then necessary to backfill and compact according to the design specifications within the subtrench. When possible, without disturbing the pipe or backfill, the trench shield can be pulled along the top edge of the subtrench. In either case, it is paramount to achieve the necessary backfill placement and compaction for a quality installation.

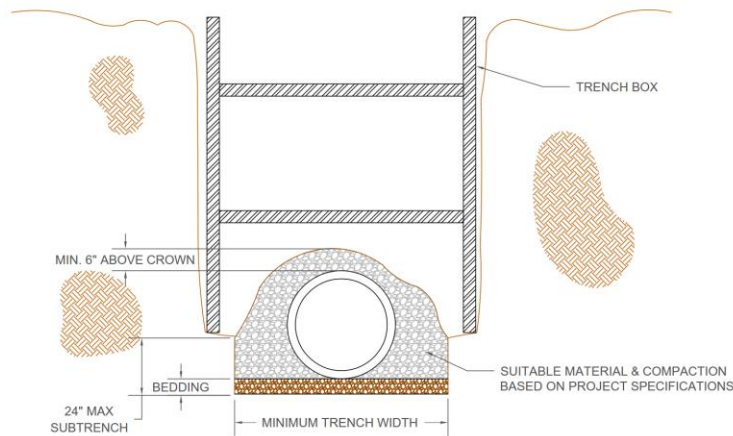

**Figure 9.11: Subtrench**

Subtrench installations also make it easier to use a geotextile around the backfill if it is required by the project specifications. The subtrench should be lined with the geotextile, and the pipe and backfill then placed over the geotextile which is wrapped over the top of the pipe/backfill system. The geotextile manufacturer may be able to provide additional information regarding the suitability of specific geotextiles for use with trench shields. The most common mistake made with a trench shield is moving it without regard to the pipe or backfill. Embedment material can be disrupted if a shield is moved without properly confining the backfill. Pipe joints can also be stressed or compromised if the shield is pulled carelessly.

The procedures described are appropriate for most cohesive and noncohesive soils; however, highly unusual soil conditions may require further investigation or different methods. Benching (i.e., forming a step-like profile on either side of the trench) or sloping (i.e., cutting back the trench wall at an angle inclined away from the trench) may also be possibilities. A qualified engineer who understands the site concerns will determine which precautions are most appropriate.

### 9.5.3 Line and Grade

Storm drain and sewer pipe systems are designed to provide hydraulic capacity based on pipe size and slope. The alignment or line of the pipe is the horizontal location of the pipe, while the grade is the vertical slope of the pipe. In order for a pipe system to function as designed, it is important to install the pipe to the proper line and grade.

Alignment is established by a field survey. Once the trench is excavated on line, the pipe bedding shall be placed to the proper thickness shown on the design plans. The bedding thickness should allow for the difference between the plan invert (flowline) and the pipe profile wall thickness.

## 9.6 Foundation Preparation

The soil at the bottom of the trench, referred to as the foundation, is a critical part of the installation. The foundation material must support the pipe and withstand the soil and live load pressures transmitted through the pipe. This material must not only provide lateral support, but also longitudinal support in order to prevent excessive differential settlement. Differential settlement may have an adverse effect on the grade. In most instances, the in-situ soil provides a suitable foundation.

### 9.6.1 Soft or Unstable Foundations

If soil doesn't move as a person walks over it, the soil is considered to be stable. If unstable soil (e.g., muck) is encountered, a typical corrective measure is to remove and replace the unstable soil with an adequate material. However, there are several methods of improving the foundation prior to installation, depending on the soil conditions present. These methods include reinforcement, restoration, and removal, described as:

- Reinforce: Soft soils are reinforced by adding dry soil, stabilizing geotextile, or geogrid materials. Soft soils can also be lime-stabilized;
- Restore: Loose soils can be restored by compacting to a higher density; and,
- Remove: Existing soils that are unusable should be completely excavated and replaced with a suitable material. This is a reliable and commonly-used method.

Each project will be unique and the method and material used to construct the foundation should be selected by a geotechnical engineer.

In the event the foundation is accidentally over-excavated, the trench bottom should be filled and brought up to grade with a structural backfill. The structural backfill should be compacted to a density equivalent to the original trench bottom in order to restore the structural integrity of the foundation.

### 9.6.2 Unyielding or Hard Foundations

Unyielding materials such as rock in the trench bottom may apply point loads where it is in contact with the pipe. Excavations in rock usually result in jagged trench bottoms. Protruding rock can create point loads, which can affect the hydraulic and structural integrity. In order to address this concern, a minimum of a 6-in. (15-cm) thick cushion of bedding below the bottom of the pipe should be installed.

## 9.7 Embedment Construction

Once the trench is excavated and a firm foundation is established, the process of installing the embedment can begin. The strength of the embedment is dependent upon the type of material and compaction level.

The recommendations for soil type and compaction level will vary based on the application. Shallow, non-trafficked installations may not require the same level of backfill quality as a shallow cover subjected to heavy live loads. Installations involving higher loads sometimes require greater soil strength. A combination of the type of material, compaction level, and burial depth determines the soil strength. When a variety of options will work in a particular installation, the final decision can depend on what is available locally in order to minimize the cost of the installation. Native soil may be specified depending on structural demand for the specific installations. Using native soil eliminates the cost of imported backfill material and the effort spent grading or hauling the excavated material off-site. Although some native materials may be classified as Class III per Table 9.1, often native soils have lower stiffness values that are similar to Class IV or higher. If the native material is not acceptable, then appropriate material should be brought into the project. Flowable fill, which is also referred to as Controlled Low Strength Material (CLSM), is another more specialized type of backfill material.

The bedding, pipe zone, and initial backfill shown in Figure 9.9 are all components of the embedment for the pipe/soil system. The following sections will discuss special considerations for the individual components of the pipe embedment.

### **9.7.1 Bedding**

The bedding material is placed in the bottom of the trench between the foundation and the bottom of the pipe. The bedding creates uniform longitudinal support and also distributes the load from the bottom of the pipe. The bedding thickness should be a minimum of 4 in. (10 cm) for 4-in. to 36-in. (10-cm to 91-cm) diameter pipe and a minimum of 6 in. (15 cm) for 42-in. to 60-in. (106-cm to 150-cm) diameter pipe.

It is recommended that bedding material is a Class I, Class II or Class III material as defined in Table 9.1. The use of Class III bedding material is recommended only in dry trench conditions. If bedding is to be used as an underdrain, then a large, coarse, clean aggregate (typically a Class I or some Class II materials) should be used. Bedding should not include clods, organic debris, frozen matter, rebar, limbs, or other unsuitable materials that may preclude uniform compaction and result in excessive localized loads and deflections (5).

The outer thirds of the bedding should be compacted and the middle one third portion should be loosely placed as shown in Figure 9.12. This loosely-placed area helps to distribute the load and to prevent hard point loading on the bottom of the pipe. The settlement of the loose bedding also helps to transfer the load to the soil in the haunch.

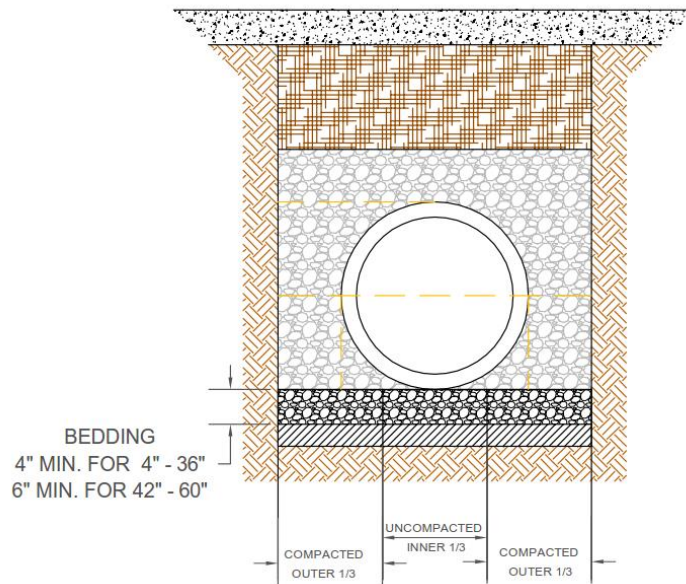

**Figure 9.12: Bedding Placement**

The bedding should be placed such that the pipe invert is at the correct grade when backfilled. There may be settlement of the pipe when placed on uncompact or loosely-placed soil. The grade should be adjusted such that the pipe invert is at the desired elevation. A backhoe bucket or similar equipment must not be used to press on the pipe to bring it to grade and the use of blocking or soil mounds under the pipe, which would cause point loading should be avoided. It is recommended that the bedding used is the same material as that used in the pipe zone and the initial backfill material.

### 9.7.2 Pipe Zone

The pipe zone material and pipe function together as a structural system, in order to support the soil overburden and any live vehicular loads. Within the pipe zone is one of the most important elements of the embedment zone, which is the haunching area. Figure 9.9 indicated that the haunching is the zone of embedment between the pipe springline and the bedding. This layer of backfill is critical to pipe performance; however, due to its location, proper placement of backfill in this layer is often overlooked. Therefore, care must be taken to place and compact the backfill in the haunching area.

The recommended soils for the pipe-zone are Class I, Class II, or Class III materials as defined in ASTM D 2321 (1) and included in Table 9.3.

**Table 9.3: ASTM and AASHTO Soil Classification**

ASTM D 2321						AASHTO		ASTM D 2487	
Class	Type	Percentage Passing Sieve Sizes				M43	M145	Notation	Description
		1 ½"	No. 4	3/8"	No. 200				
		40 mm	4.75 mm	9.53mm	0.075 mm	Notation	Soil Groups		
I <sup>(1)</sup>	Crushed Rock Angular	100%	≤15%	≤25%	≤12%	5	NA	N/A	Angular crushed stone or rock, crushed gravel, broken coral, crushed slag, cinders or shells; large voids with little or no fines
	Manufactured processed aggregates; dense-graded, clean	100%	≤50%	≤25%	≤12%	56	NA	N/A	Angular crushed stone material and stone/sand mixtures; little or no fines
II <sup>(1)</sup>	Coarse-Grained Soils, clean	100%	<50% of "Coarse Fraction"		<12%	57	A1, .A3	GW	Well-graded gravel, gravel/sand mixtures; little or no fines
						6	A1, .A3	GP	Poorly-graded gravels, gravel sand mixtures; little or no fines
			>50% of "Coarse Fraction"		<12%	67	A1, .A3	SW	Well-graded sands, gravelly sands; little or no fines
								SP	Poorly-graded sands, gravelly sands; little or no fines



	Coarse-Grained Soils, borderline clean/fines		Varies		5% to 12%			e.g. GW-GC, SP-SM	Sands and gravels which are borderline between clean and with fines
III	Coarse-grained soils with fines	100%			>12%	Gravel and sand with <10% fines	A-2-4, A-2-5 or A-2-6	GM <sup>(2)</sup>	Silty gravels, gravel/sand/silt mixtures
								GC <sup>(3)</sup>	Clayey gravels, gravel/sand/clay mixtures
								SM <sup>(4)</sup>	Silty sands, sand/silt mixtures
								SC <sup>(5)</sup>	Clayey sands, sand/clay mixtures
	Fine-Grained Soils (inorganic)	100%`			<30%		A-4 or A-6	ML <sup>(6)</sup>	Inorganic silts and very fine sands, rock flour, silty or clayey fine sands, silts with slight plasticity
							CL <sup>(7)</sup>	Inorganic clays of low to medium plasticity; gravelly sandy, or silty clays; lean clays	

Notes:

1. Non Plastic as defined by ASTM D2487.
2. Plastic index <4 or "A" line, as defined by ASTM D2487.
3. Plastic index <7 or <"A" Line, as defined by ASTM D2487.
4. Plastic index >4 or <"A" Line, as defined by ASTM D2487.
5. Plastic index >7 or <"A" Line, as defined by ASTM D2487.
6. Liquid Limit <50 and plastic index <4 and <"A", as defined by ASTM D2487.
7. Liquid Limit <50 and plastic index >7 and ≥"A", as defined by ASTM D2487.

A general recommendation included in ASTM D2321 (1) is to limit the maximum particle size in the pipe zone soil in accordance with Table 9.4.

**Table 9.4: Maximum Embedment Particle Size**

Diameter	Particle Size
< 8 in. (20 cm)	≤ 10% of the diameter, in. (cm)
8 – 15 in. (20-38 cm)	≤ 3/4 in. (1.9 cm)
>15 in. (38 cm)	≤ 1 ½ in. (3.8 cm)

### 9.7.3 Initial Backfill

The initial backfill serves as a layer of protection and helps to distribute loads away from the pipe into the pipe zone and it should be Class I, II, or III soil. The maximum particles should be designed in accordance with Table 9.4. Soil within the embedment zone should not contain any organic material, stumps, logs or limbs, man-made waste, debris, frozen soil, or any other unsuitable material. Meeting the requirements for the soil in the embedment zone is absolutely critical to obtaining the maximum structural performance and service life. Any changes to the material recommendations should be approved by the specifying agency or Engineer of Record.

### 9.7.4 Soil Compaction Density

Minimum compaction levels are typically specified as part of the installed pipe system design. Each portion of the embedment should be compacted in lifts, or layers, during installation. The type of material used will determine the height of the lifts and the percent compaction necessary in order to achieve the desired pipe support. Table 9.5 contains the applicable compaction requirements based on soil types, and Table 9.6 contains lift height recommendations.

**Table 9.5: Backfill Placement and Compaction Recommendations <sup>1</sup>**

	Class I <sup>2</sup>	Class II <sup>3</sup>	Class III <sup>4</sup>	Class IV
General Recommendations and Precautions	Suitable for use as a drainage blanket and underdrain in rock cuts where adjacent material is suitably graded. Use in conjunction with non-woven geotextile filter fabric where conditions may cause migration of fines from adjacent soil and loss of pipe support.	Check gradation to minimize migration of fines in conditions where hydraulic gradients exist. "Clean" groups suitable for use as drainage blanket and underdrain. Uniform SP materials (fine sands) with > 50% passing a #100 sieve behave and should be treated as silts.	Should not be used where water conditions in trench may inhibit proper compaction.	Not Recommended
Foundation	Foundation material is suitable for replacing over-excavated and unstable trench bottom as cautioned above. Install and compact in 12-in. maximum layers.	Foundation material is suitable for replacing over-excavated and unstable trench bottom as cautioned above. Install and compact in 12-in. maximum layers.	Foundation material is suitable for replacing over-excavated and unstable trench bottom as cautioned above. Install and compact in 6-in. maximum layers.	Not Recommended

Bedding	Install in 12-in. maximum layers. Level final grade by hand. Minimum depth 4-in.thru 36” diameter and 6-inch for ≥ 42” diameter  (6-in. in rock cuts).	Install and compact in 6-in. maximum layers. Level final grade by hand. Minimum depth 4 in for pipe sizes .thru 36” diameter and 6-inch for ≥ 42” diameter.  (6 in. in rock cuts).	Suitable only in dry trench conditions. Install and compact in 6-in. maximum layers. Level final grade by hand. Minimum depth 4-in for pipe sizes thru 36” diameter and 6-inch for ≥ 42” diameter.  (6 in. in rock cuts).	Not Recommended
Haunching	Install and compact in maximum layers of 6-in. or 1/3 of pipe diameter, whichever is less. Work in around pipe by hand to provide uniform support.	Install and compact in 6-in. maximum layers. Work in around pipe by hand to provide uniform support.	Install and compact in 6-in. maximum layers. Work in around pipe by hand to provide uniform support.	Not Recommended
Embedment Compaction	Minimum compaction - Place and work by hand to insure all excavated voids and haunch areas are filled.	Minimum density 85 % compaction density for SW and SP soils. For GW and GP soils compact with at least two passes of compaction equipment	Minimum density 90 % Compaction Density. Maintain moisture content near optimum to minimize compaction effort.	Not Recommended
Initial Backfill	Install to a minimum of 6 in. above pipe crown.	Install and compact to a minimum of 6 in. above pipe crown.	Install and compact to a minimum of 6 in. above pipe crown.	Not Recommended

Final Backfill	Compact as required by the Engineer.	Compact as required by the Engineer.	Compact as required by the Engineer.	Compact as required by the Engineer.
----------------	--------------------------------------	--------------------------------------	--------------------------------------	--------------------------------------

Notes:

1. See ASTM D 2321 for a detailed description and classification of materials.
2. Since the in-place density of Class I material is difficult to measure, the soil should be compacted in lifts with a maximum thickness of 18 inches and compacted with vibratory equipment. Class I material is placed either compacted or uncompacted.
3. Class II material should be placed at a minimum of 85% compaction density for SW and SP soils. For GW and GP soils a minimum of two passes with compaction equipment. The GW and GP soils should be compacted with vibration while the SW and SP soils can be compacted with either vibration or impact.
4. Class III soils should be compacted with impact methods.

Class I or clean crushed stone generally does not require compaction but must completely fill the haunch area to minimize large voids. This is accomplished by knifing the material under and around the pipe with a spade or other type of slender rod. Other materials require greater compaction and the level of compaction should be determined by the project engineer, or a geotechnical engineer based on the soil properties and the site conditions.

It is important to avoid contact between the pipe and the compaction equipment. Compaction equipment should not be used directly over the pipe crown until sufficient backfill has been placed in order to ensure that the compaction equipment will not damage or cause deflection in the pipe.

Proper selection of compaction equipment depends on the type of backfill material being compacted. Table 9.6 summarizes backfill material soils and the associated equipment types and effort required to achieve compaction.

**Table 9.6: Compaction Effort and Equipment**

	Soil Classification <sup>(1)</sup>			
	Class I	Class II	Class III	Class IV
Effort Required	Low	Moderate	High	Very High
Equipment Type	Hand Knifing in Haunch, Vibratory, or Impact	Vibratory, or Impact	Impact	Impact
Moisture Control	None	None	Near optimum to minimize compaction effort	Near optimum to achieve required density
Maximum Pipe Zone Lifts	18"	12"	6"	NA

Note:

1. See ASTM D 2321 (1) or Table 9.3 for a detailed description and classification of material. Class IV materials are not acceptable for embedment.

### 9.7.5 Mechanical Compaction Equipment

The desired compaction level may be achieved using common compaction equipment which may include hand tampers, power tampers, static compactors, vibratory compactors, or rammers. A few of the compactor types are shown in Figure 9.13.



(a)



(b)



(c)

**Figure 9.13: Typical Compaction Equipment (a) vibratory plate equipment used for Class I and Class II soils; (b) impact plate equipment used for all soil types; (c) self-propelled vibratory roller used for Class I and Class II soils.**

In order to eliminate the possibility of damaging the pipe, a minimum of 3 ft (0.9 m) of cover should be achieved before large, self-propelled compactors are used over or around the pipe. Hydro-hammers or other tractor-mounted hydraulic vibratory and impact compaction equipment should not be used until a minimum of 4 ft (1.2 m) of cover is over the pipe. The pipe interior should be checked regularly to see if compaction or loading has deformed the top of the pipe.

Soil jetting is a process by which a long hose or other device is worked down into the soil with a high velocity stream of water and is then pulled out slowly, compacting the soil as it is removed. This process is not recommended for use within the pipe zone, although it may be suitable for the final backfill layer. Jetting should only be used when approved by an engineer.

## 9.8 Final Backfill

Final backfill, which extends from the initial backfill layer to the ground surface, does not directly support the pipe. The percent compaction requirement for the final backfill for trench installations can range from uncompacted to 85% in cultivated lands, or to 95% beneath roads and parking lots. Excavated materials may be of adequate quality for final backfill, depending on the intended use at the surface. When placing final backfill, consideration should be given to the compaction equipment and any associated construction loads operating over top of the pipe. Proper compaction of the final backfill area is not nearly so critical for the pipe as in the other layers; however, if roads or driveways will be crossing over top of the pipe, a relatively high degree of compaction is needed to prevent pavement settlement. Local and state agency requirements will usually control the final backfill compaction needs. Selection, placement, and compaction of the final backfill will be as directed by the design engineer.

### 9.8.1 Minimum Cover Height

Cover height is one of the determining factors when calculating the load-carrying capacity of the installation. Minimum cover heights are dependent on the backfill material used and the expected live loads. With the minimum cover heights found in Table 9.7, CPP will withstand AASHTO HL93 highway loads (4).

**Table 9.7: Minimum Cover Heights**

Pipe Diameter	Minimum Cover Required <sup>(1)</sup>
4 in. – 48 in. (10 cm – 121 cm)	12 in. (30 cm)
54 in. and 60 in. (137 cm and 152 cm)	18 in. (45 cm)

Note: (1) Minimum cover is measured from the top of the pipe to bottom of flexible pavement or to the top of rigid pavement.

These cover heights assume 6 in. (15 cm) of structural backfill over the pipe crown with an additional layer of compacted sub-base material or rigid pavement to achieve the minimum requirements.



## 9.8.2 Maximum Cover Height

Increased cover heights can allow for live loads to be distributed over a greater area of surrounding soil; however, it also adds to the weight of the soil column directly above the pipe. Maximum cover heights are dependent on many variables, including the level of the ground water table, the backfill material used, and the level of compaction.

## 9.9 Other Installation Considerations

Other important considerations for the proper installation of corrugated CPP are introduced in the following sections but it is often advisable to contact the pipe manufacturer for additional guidance.

### 9.9.1 Connections to Manholes or Other Structures

Where the pipe connects to a structure, such as a manhole, there are two important considerations: (1) the integrity of the connection, and (2) its ability to manage any differential settlement between the two components. The integrity of the pipe-to-manhole connection should be based on the site conditions. For most site conditions, a soil tight pipe-to-structure connection is sufficient for long term performance and the integrity of the pipe-to-structure connection. Certain site conditions require a watertight connection and these include: high ground water with fine native soils; and storm sewer systems subjected to prolonged surcharged conditions. Certain types of connections also allow for differential settlement, or alternatively, a transition segment can be used to manage the movement.

For non-watertight applications, it may be acceptable to place non-shrink grout in the void space between the CPP and concrete structure as shown in Figure 9.14. The corrugations in combination with the non-shrink grout provide an excellent seal.

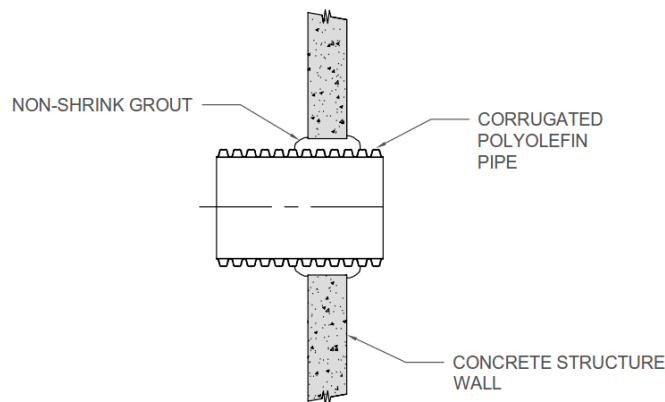

**Figure 9.14 Grouted Concrete Structure Connection**

Figure 9.15 illustrates the gasketed and grouted connection, which includes a rubber gasket that is designed to fit the cut pipe with full height corrugations. Some manufacturers have specially-designed rubber gaskets for these types of connections and it is advisable to contact the manufacturer for gasket recommendations. The gasket provides a surface to which the grout can adhere and it can also minimize chances of water piping along the exterior pipe wall, in order to ultimately result in a tighter seal.

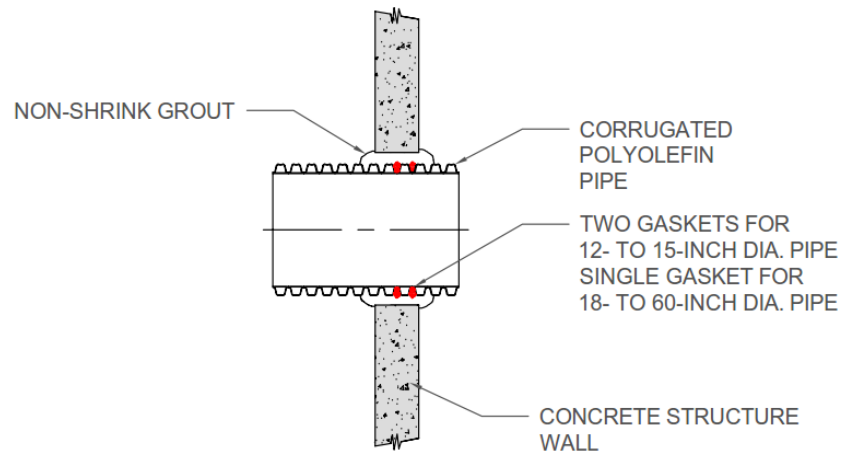

**Figure 9.15: Gasket and Grouted Concrete Structure Connection**

If the pipe system will be pressure-tested for water-tightness, it is necessary to provide additional measures to ensure a watertight connection between the pipe and the structure. The ASTM F2510/F 2510M *Standard Specification for Resilient Connectors Between Reinforced Concrete Manhole Structures and Corrugated High Density Polyethylene Drainage Pipes*, is the governing standard for corrugated HDPE pipe-to-manhole connections (5), but specific performance and installation requirements should be verified for each project. Common connection methods that provide varying levels of water tightness are discussed in this section, but individual manufacturers may have additional methods of joining the pipe to the structure.

Figure 9.16 illustrates a rubber boot to smooth exterior CPP adaptor connection. This type of connection uses a manufacturer's CPP pipe to concrete structure adaptor that has a smooth outer surface that slips into a flexible boot-type connector. A clamp or other mechanism forms a tight connection with the adapter and the flexible connector. It should be noted that different CPP manufacturers may have different outside diameters (i.e., the dimension, A, in Figure 9.16). Therefore, the outside diameter dimensions of the smooth exterior CPP adaptor must be understood before ordering a flexible connector.

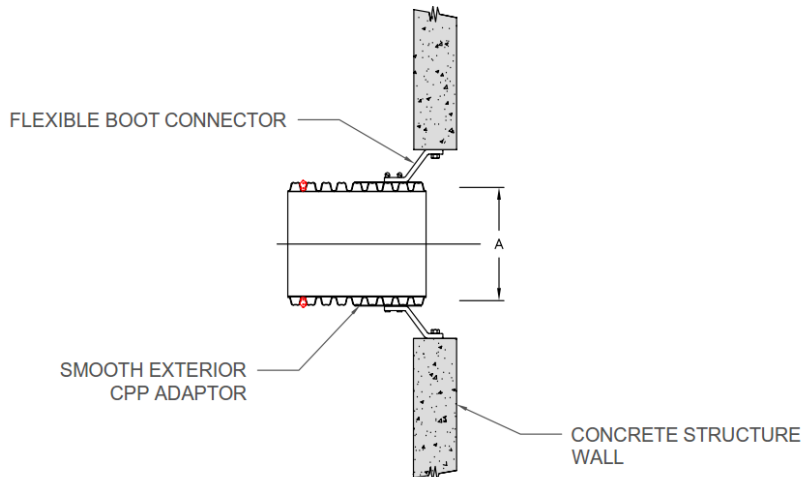

**Figure 9.16: Rubber Boot to Smooth Exterior Pipe Connection**

The cast-in-place rubber seal to smooth exterior CPP adaptor connection is shown in Figure 9.17. This type of connection uses a manufacturer’s CPP pipe to concrete structure adaptor having a smooth outer surface that slips into the cast-in-place rubber seal. A rubber seal which is cast into the concrete structure wall during the manufacturing process of the concrete structure accepts the smooth exterior CPP adaptor in order to form a watertight connection. Therefore, the outside diameter dimensions of the smooth exterior CPP adaptor must be dimensionally compatible with the cast-in-place rubber seal.

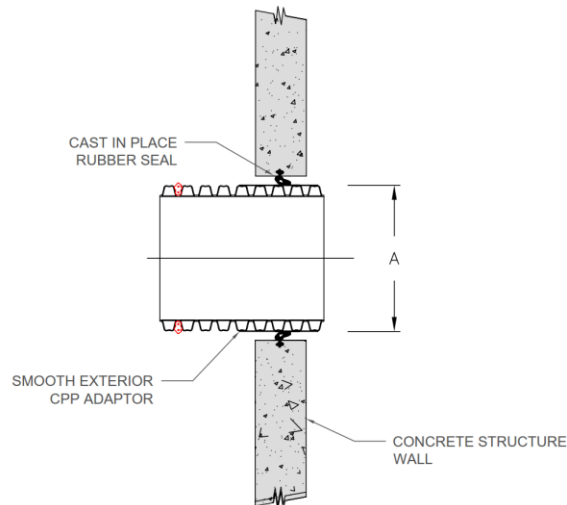

**Figure 9.17: Cast in Place Rubber Seal to Smooth Exterior Connection**

When installing a smooth exterior CPP adaptor into cast-in-place rubber seal or a rubber booted connection, the fitting may be over inserted into the structure temporarily while the adjoining pipe is laid. The smooth exterior CPP adaptor is then pushed back through the structure to insert the spigot end into the bell end in order to fully assemble the joint together. A typical application of this technique is shown in Figure 9.18.

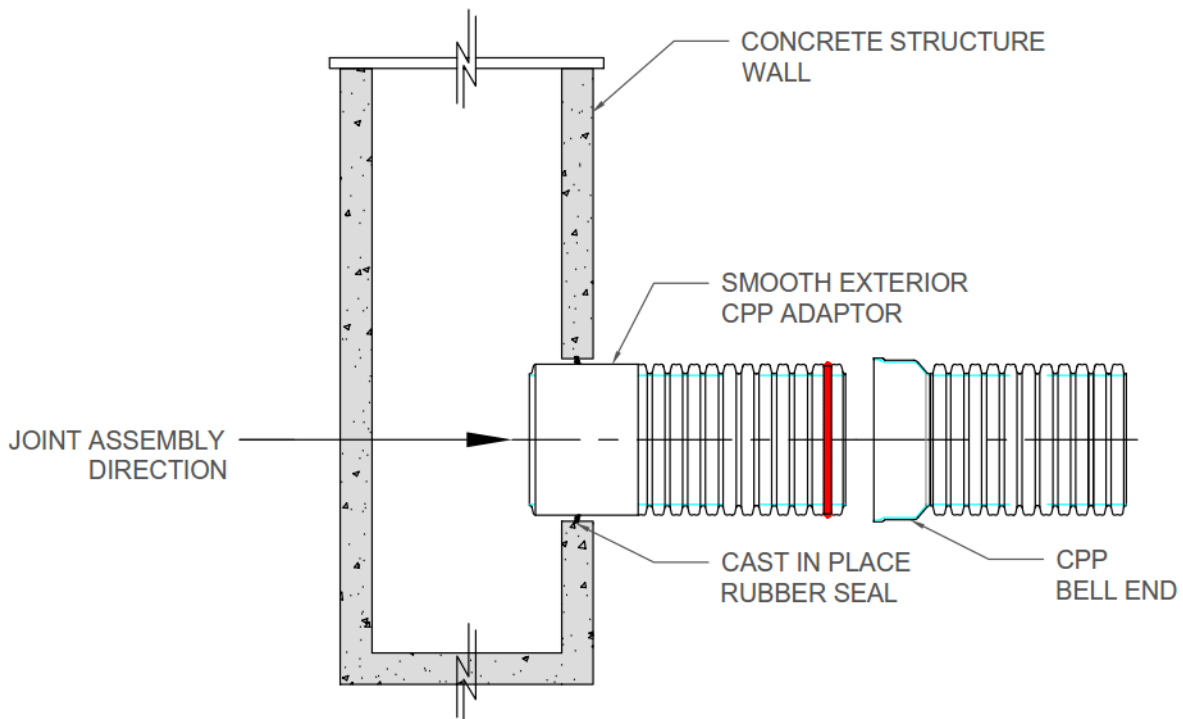

**Figure 9.18: Adapter Assembly Upstream End**

When using a smooth exterior CPP adaptor in the downstream end of the structure, and before pushing the bell and spigot together, it is necessary to provide blocking at the inside of the structure in order to prevent the fitting from moving in the structure, as shown in Figure 9.19.

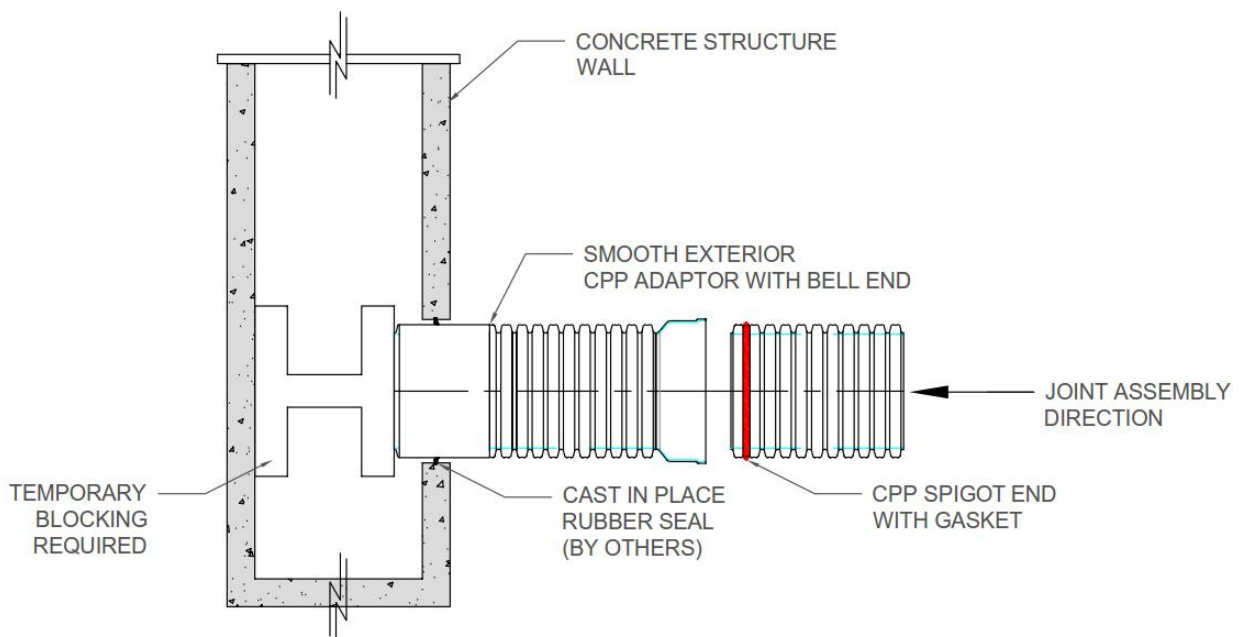
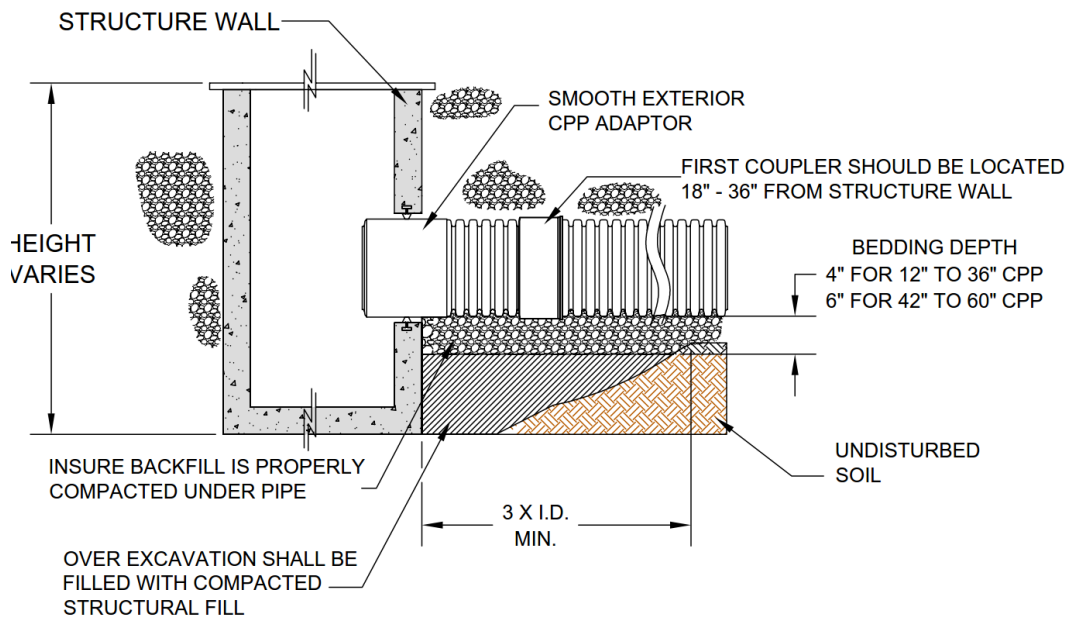

**Figure 9.19: Adapter Assembly Downstream End**

The selection of which concrete structure connection is most suitable for a project is based on the joint and connection requirements, along with preferred concrete structure connection method for the region. It is important to note that prevailing regulations should be consulted before selecting a concrete structure connection.

### 9.9.2 Accommodating Differential Settlement Between Pipe and Structures

Proper installation of the pipe and structure will minimize settlement, but some differential settlement may still occur at the connection. Differential settlement can be accommodated by placing a short length of pipe (typically, 18 in. to 36 in. (45 cm to 90 cm) long) between the structure and the full pipe length. This short stub of pipe provides a pivot point and absorbs some of the vertical shear created by the settlement. Figure 9.20 provides a detailed illustration of this connection.



**Figure 9.20: Pipe to Structure Connection**

### 9.9.3 PVC Drain Basins

PVC drain basins like the one shown in Figure 9.21 can also be used as a collection point where two or more drain lines converge. PVC basins provide a transition between different sizes and types of pipe, and can also change the elevation or direction of the pipe. Structures are shipped with rubber gaskets to ensure a watertight connection. This prevents the soil infiltration and any long term settlement around the basin. Flexible connections allow minor movement to take place without compromising the structural or watertight integrity of the basin. Additionally, the need to wait for grout set-up is eliminated. The product is lightweight and handled easily, which can translate into a faster installation time with less equipment and personnel and implies a lower total cost. Basins are easily adjustable in the field to meet final grade. In addition, last-minute trimming or extensions are easily made to ensure proper positive drainage is achieved.

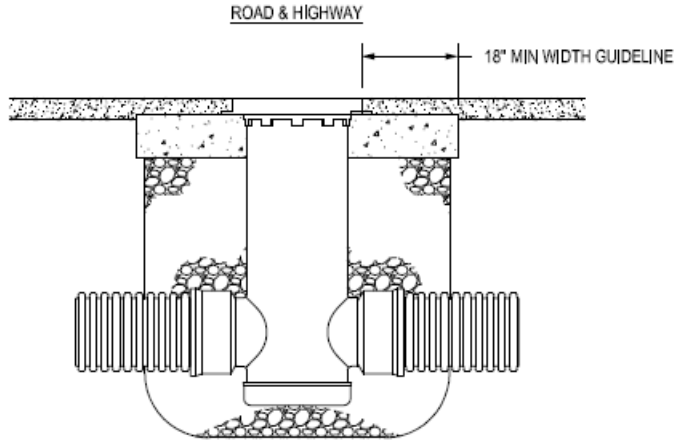

**Figure 9.21: PVC Drain Basin**

### 9.9.4 Construction and Paving Equipment

Often during the paving process, it is necessary to drive over pipe which has less than the minimum amount of cover during the period in which the pavement is being placed. Many types of paving equipment are not as heavy as the design load. For temporary construction loads, such as pavers, the minimum allowable cover height is governed by the pressure at the surface of the soil. The pressure is a result of the vehicular load distributed over the tire contact patches. For these lower soil pressure situations with relatively light construction vehicles, the minimum cover criteria can be temporarily decreased during the construction phase; however, some rutting may still occur at the surface. Table 9.8 presents the minimum cover heights for temporary construction loads.

**Table 9.8: Minimum Cover for Temporary Construction Loads**

Example Vehicle	Vehicular Load at Surface <sup>1</sup> , psi (kPa)	Temporary Minimum Cover by Diameters	
		4 to 48 in. (10 to 122 cm) Diameter Pipe <sup>(1)</sup>	54 and 60 in. (137 and 150 cm) Diameter Pipe <sup>(1)</sup>
Semi-tractor <sup>2</sup>	75 (157)	9 in. (23 cm)	12 in. (30 cm)
Loaded pick-up Truck <sup>3</sup>	50 (345)	6 in. (15 cm)	9 in. (23 cm)
Skid steer loader <sup>4</sup>	25 (172)	3 in. (7.6 cm)	6 in. (15 cm)

Note:

1. Vehicles exceeding surface pressures must not be allowed over the installation with these temporary minimum covers.
2. Based on typical 3-axle day trip tractor without trailer.

3. Chevy® 3500 Series, fully loaded.
4. Bobcat® T180 Model skid steer loader.

Very heavy construction traffic poses additional concerns for pipe when buried at shallow depths. The extremely high loads created by construction vehicles can potentially reduce the safety factors below the reasonable levels in minimum cover conditions. It is recommended that 3 ft (0.9 m) of cover be maintained over the pipe in installations involving construction vehicles that weigh between 30 tons (27 metric tons) and 60 tons (54 metric tons). For heavier vehicles, a greater amount of cover may be required depending on the load and loading footprint. The pipe manufacturer can assist with the specific vehicle load and footprint information regarding any further precautions that might be necessary. Additional cover can be mounded and compacted over the pipe during the construction phase. If rutting occurs, more cover should be added in order to ensure the minimum amount of cover is maintained. After construction vehicles are finished working above the pipe, the extra cover can be graded. As shown in Figure 9.22. If in a particular installation the pipe already has the minimum amount of cover, then no additional precautions are necessary.

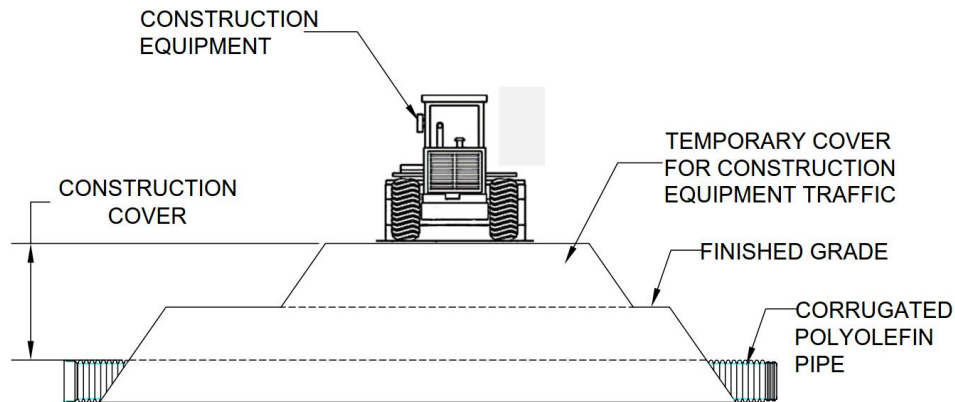

**Figure 9.22: Construction Loads Minimum Cover**

### 9.9.5 Curvilinear Installations

When a change in alignment is required, CPP can be assembled as a series of straight pipes with small angular misalignment at the joints, as illustrated in Figure 9.23. However, the maximum recommended amount of joint articulation (or angle) that the pipe can be misaligned is determined by each pipe manufacturer, consistent with the type of coupler and the joint tightness. In order to maintain the integrity of the joint, the angular offset must not be exceeded.

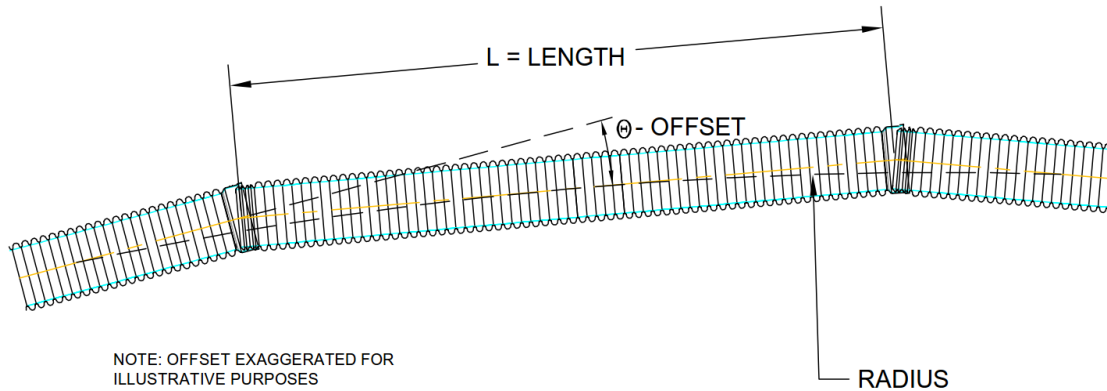

**Figure 9.23: Curvilinear Configuration**

Based on the allowable misalignment for the joint, the calculation in Eqn. 9.1 may be used to determine either the resulting radius of curvature or the pipe section length needed to obtain the target radius. The pipe itself should not be bent, and calculations do not assume any bend in the pipe.

$$R = \frac{L}{\tan \theta} \quad (\text{Eqn. 9.1})$$

where:

- R = Radius of curvature, ft (m);
- L = Lay Length of pipe section, ft (m); and,
- $\theta$  = Misalignment angle, degrees.

### 9.9.6 Groundwater Control

Excessive groundwater hinders the proper placement of the pipe and backfill. The pipe may float in certain conditions which makes it difficult to maintain its position. Excessive water can make it difficult to place some backfill materials and to properly compact them to minimum requirements. In order to minimize difficulties in obtaining proper compaction, and the impact of groundwater on structural integrity of the backfill material, Class I and select Class II materials (such as GW and GP) are recommended and these materials were defined in Table 9.3. Despite the use of these bedding materials, standing water in the trench can create a number of challenges. These challenges include difficulty checking the uniformity of the bedding surface, proper bell holes that cannot be verified, and grit on the joint surfaces that can affect its integrity. When a specification states that the pipe should be laid in a dry trench, the water must be kept at a level that does not prevent proper placement of either the pipe or the backfill throughout the pipe zone. Generally, the top of the bedding material should be visible before the pipe is laid.



Dewatering procedures are very site-specific and may require well points, drainage blankets, and/or sump pumps to keep the groundwater at a manageable level. Managing the systems should be well coordinated with the excavation activities. When Class I and II soils are used as bedding and pipe zone material, a French drain is created. In order to prevent disrupting the area groundwater regime or diverting underground streams, trench plugs may need to be constructed periodically along the alignment.

### **9.9.7 Flowable Fill Backfill Material**

Flowable fill can be used in the pipe zone as an alternative to compacted granular backfill and can achieve comparable soil stiffness values to those of Class I material. It is a mixture composed primarily of Portland cement, soil, and water that hardens after placement. Flowable fill is produced by ready-mix companies or it can be made at the jobsite in some cases. In order to ensure the material can be easily removed when necessary, the compressive strength should be between 40 and 80 psi (276 and 551 kPa) at 7 days. It can be used to provide a high quality installation in situations where conventional backfilling methods may be difficult or unsafe, and allows the pipe to be installed in somewhat narrower trenches.

Since the trench width for flowable fill is typically less than for conventional backfill, it can allow pipe to be installed in or around restrictions. The trench must be wide enough for the material to flow easily around the pipe and into the haunch areas. Table 9.9 provides minimum trench widths that work well in most flowable fill installations, while still allowing for pipe placement and jointing.

**Table 9.9: Minimum Trench Width for Flowable Fill**

Nominal I.D. in. (cm)	Minimum Trench Width, in. (cm)
12 (30)	18 (45)
15 (38)	22 (56)
18 (45)	27 (68)
24 (60)	35 (89)
30 (75)	44 (111)
36 (91)	51 (129)
42 (106)	60 (150)
48 (122)	67 (170)
54 (137)	76 (193)
60 (150)	83 (211)

Notes:

1. Minimum trench widths assume stable and high bearing capacity trench walls.
2. Verify pipe outside diameter with manufacturer since outside diameters may vary. Minimum trench width is pipe outside diameter times 1.25 (i.e. OD X 1.25). Contact the pipe manufacturer for minimum trench width for diameters less than 12 in. (30 cm).
3. In soft in-situ materials a wider trench width may be necessary.

Granular bedding shown in Figure 9.24 generally provides sufficient support for the pipe. However in certain conditions where the in-situ soils are soft, it may be necessary to ensure that flowable fill is under the pipe. For these conditions, soil pads should be placed at intervals along the trench bottom, and then the pipe can be positioned on them. These will allow the flowable fill to get under the pipe itself and provide uniform support to the invert. The height of the soil pad and the frequency of soil pads is dependent of the specific site conditions. It is advisable to contact a pipe manufacturer or a qualified engineer for specifics regarding the soil pad design.

In order to prevent pipe flotation and misalignment, the flowable fill should be poured in incremental lifts uniformly on either side of the pipe. Each lift should be allowed to harden before the next lift is poured and the time it takes for each lift to harden depends on the particular mixture and ambient conditions. The design engineer should provide guidance on how long to wait between pours. Figure 9.24 shows the relationship between pipe diameter and lift height.

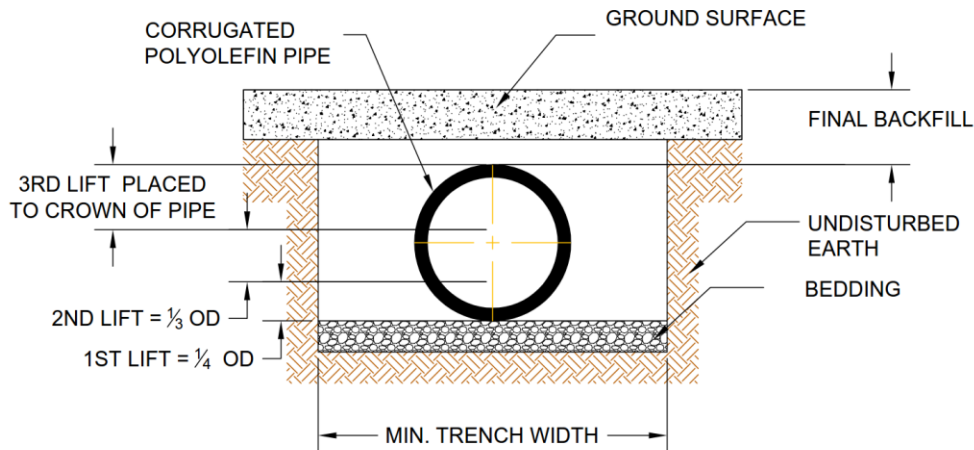

**Figure 9.24: Flowable Fill Lifts**

In lieu of pouring in layers, flowable fill can also be poured in one continuous lift provided proper flotation restraints have been installed. Because fill is flowable a fluid when it is poured around the pipe, some precautions must be taken during installation so that it does not misalign or float the pipe. Moisture is beneficial to curing, so it may be desirable to place a thin layer of soil (e.g., 6 in. (15 cm)) on top of the flowable fill section in order to enhance the curing.

Common methods to prevent flotation include the use of dikes of flowable fill or native material placed at intervals along the pipe to hold it down, or rebar placed in an “X” pattern above the pipe and anchored into the trench sidewall. Additional methods may include a pre-cast concrete swamp weight or a commercially-available screw anchor assembly. Anchor design and spacing may require design by the project engineer and additional information on the use of flowable fill can be found by contacting the pipe manufacturer or a qualified engineer. The use of plasticizers or other admixtures can greatly affect cure time and final compressive strength. For most construction projects, work can resume approximately 4 to 6 hours after final placement.

### 9.9.8 Geotextiles

When the groundwater table is at or above the elevation of the pipe, fine particles from the in-situ soil and/or the final backfill may migrate into the coarse backfill, which can result in a loss of pipe support or settlement of soil in the pipe area. In order to prevent the migration of fine soil particles into the embedment, the use of a non-woven geotextile may need to be considered. The use of woven geotextiles have been found in practice to provide little if any prevention of soil fines migration and are not recommended for this application. The geotextile will act as a filter around the bedding, haunch, and initial backfill and may prevent this migration from occurring.

### **9.9.9 Groundwater/Pipe Flotation**

Pipe flotation may be a concern for pipe systems installed in areas where seasonal or permanent water tables extend above the pipe. This concern is exacerbated for watertight pipe systems and installations in poorly graded non-cohesive soils. In all cases it is important to consider the minimum cover heights necessary to prevent floatation. Depending on the site conditions these minimum cover heights may be greater than required for structural considerations. In applications where pipe buoyancy is too great for the soil load present, earth anchors or poured concrete collars may be used to secure the pipe to grade.

Factors effecting flotation include, but are not limited to, soil type, density of the soil, amount of cover over the top of the pipe, height of water table, weight of the pipe, and amount of effluent in the pipe. Flotation can also be encountered during the process of backfilling with flowable fill. Some of the options which will provide adequate downward force to overcome the buoyant force where flotation may be a concern are listed.

#### ***Option I - Proper fill over the pipe***

Weight provided by fill over the top of the pipe may create enough downward force to overcome the buoyant force created by water surrounding the pipe. Minimum cover for each diameter can be calculated as explained in detail in Chapter 7. However, if the pipe is installed in an area prone to high groundwater and the cover height is less than 65% of the inside diameter of the pipe, then buoyancy should be evaluated as shown in Table 9.10.

**Table 9.10: Minimum Cover Required to Prevent Flotation**

Nominal Diameter in. (cm)	Minimum Cover in. (cm)
4 (10)	3 (7)
6 (15)	4 (10)
8 (20)	5 (13)
10 (25)	7 (17)
12 (30)	9 (23)
15 (38)	11 (28)
18 (45)	13 (33)
24 (60)	17 (43)
30 (75)	22 (56)
36 (90)	25 (63)
42 (106)	29 (73)
48 (120)	33 (84)
54 (137)	37 (94)
60 (150)	40 (101)

Notes:

1. Minimum cover assumes the pipe is empty. Water in the pipe will reduce the minimum cover requirement.
2. Typical pipe outside diameter (O.D.) was used to generate this table. Pipe O.D. may vary based on manufacturer. Consult the pipe manufacturer for product specific minimum cover requirements.
3. Water table assumed to be at ground surface and saturated soil density was 130 pcf (2082 kg/m<sup>3</sup>). Greater soil density or lower water table will reduce minimum cover height to prevent floatation.

**Option 2 - Concrete saddles**

If insufficient cover is available to prevent flotation, physical anchoring of the pipe to the foundation may be required. One option is the use of concrete weights or saddles to encase sections of the pipe, as seen in Figure 9.25. The dimensional design of the concrete saddle is the responsibility of the project’s design engineer and is based on factors such as pipe diameter and the expected height of water surrounding the pipe. The location of the concrete saddles along the length of the pipe should be specified by the design engineer. Among other factors, the determination of the concrete saddle leg spacing should account for the expected impact on the deflection of the pipe.

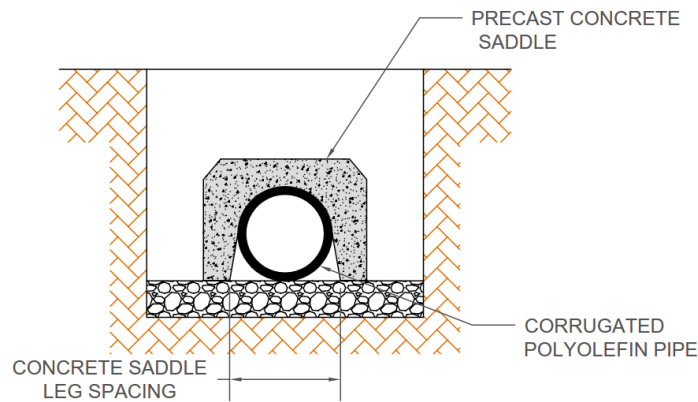

**Figure 9.25: Precast Concrete Saddles**

**Option 3 - Staking**

Staking the pipe will prevent flotation by holding the pipe in place with straps or anchors screwed directly into the ground. When trench bottom conditions are stable and able to offer restraint, the CPP pipe can be staked as shown in Figure 9.26. The guy screw and harness ring should be set adjacent to the pipe joints. Backfill operations should then proceed as usual with the staking left in place. It is important to make sure that no voids are left in the haunch area near the stakes. Additionally, the anchor guy wire vendor should be consulted to ensure sufficient restraint forces for the buoyant conditions.

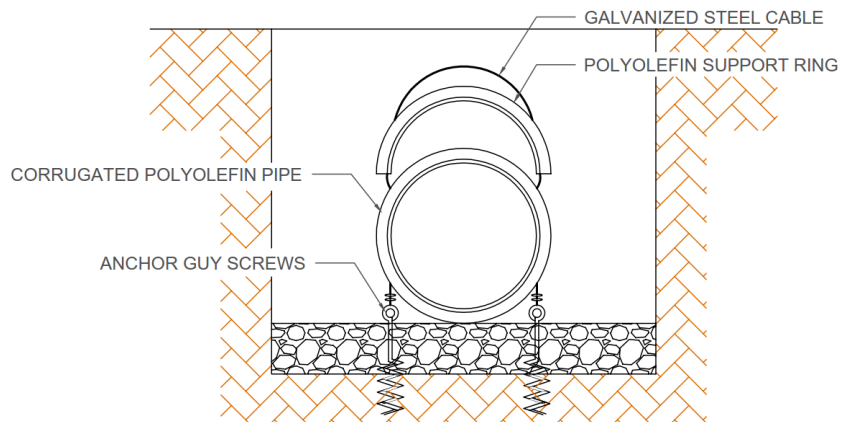

**Figure 9.26: Typical Anchor Guy Screw Configuration**

For any questions regarding the application or use of other anchoring methods, contact the CPP manufacturer or a qualified engineer.

### **9.9.10 Jointing Different Pipe Types or Sizes**

Occasionally, a drainage project will use more than one type of pipe material or profile. There are numerous ways to connect CPP to dissimilar products; however, options to make these transitions are often limited by the required joint quality. The CPP industry offers a wide array of adapter fittings specifically made for connections to corrugated metal pipe as well as concrete pipe and structures. Additionally, the fabrication of special connections is often an option when time permits.

One very common method of connecting different types of pipe of the same size, and in some cases different sizes, is through the use of a concrete collar. This generally provides a minimum silt-tight joint quality but ultimately depends upon workmanship. A concrete collar is formed by butting the two pipe ends together, wrapping the junction with a geotextile to prevent intrusion of most soil and concrete, and then pouring a concrete collar that covers both pipe ends. Devices such as Mar Mac coupler® and the Seal-Tite® coupler are also helpful to making these transitions.

In other cases, a specially-designed fitting may be warranted for use in combination with another manufacturer's gasket in order to complete the transition. Transitions made in this manner may offer a higher degree of watertight integrity than a concrete collar.

### **9.9.11 Parallel Pipe Installation**

In some applications, such as underground detention systems or high volume fluid conveyance, it may be desirable to run multiple parallel pipelines in the same trench. In this situation, the trench width is a function of the number of runs, the adequate spacing between the pipes, and the adequate space between the pipe and the trench walls as shown in Table 9.11. A minimum amount of backfill is needed to provide adequate side support and a minimum spacing is also needed to compact the fill properly to develop this support. Generally accepted minimum spacing between pipes is 12" or ½ the pipe diameter, whichever is greater. Minimum pipe spacing requirements are shown in Table 9.11. These recommendations assume that there are no fittings connecting the two adjacent runs; however, if fittings are used, then the spacing recommendations will differ.

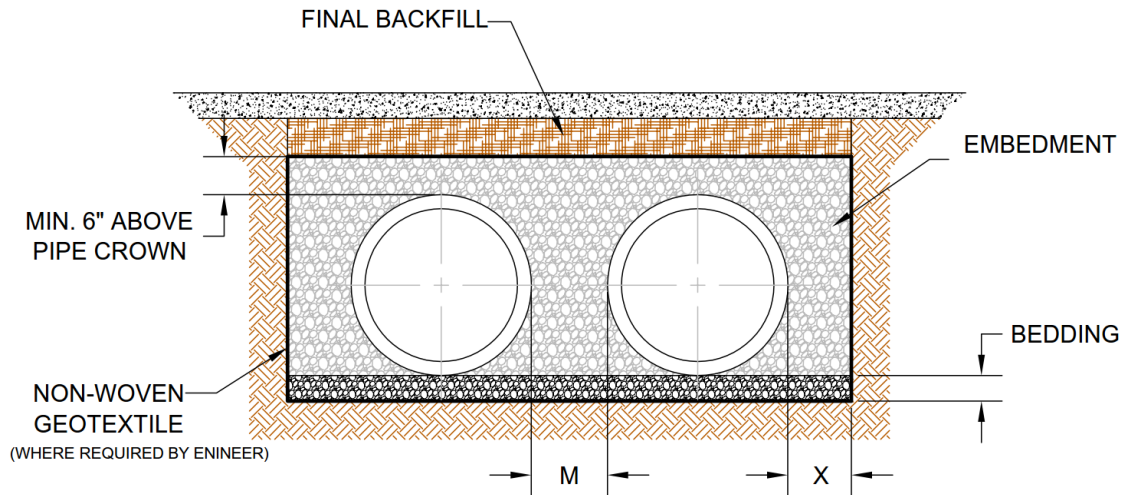

**Figure 9.27: Parallel Pipe Configuration**

**Table 9.11: Parallel Pipe Installation Spacing**

Nominal I.D., in. (cm)	Min. Side Wall "X" in. (cm)	Minimum Spacing "M" in. (cm)
12 (30)	8 (20)	12 (30)
15 (38)	8 (20)	12 (30)
18 (45)	9 (23)	12 (30)
24 (60)	10 (25)	12 (30)
30 (75)	18 (45)	15 (38)
36 (91)	18 (45)	18 (45)
42 (106)	18 (45)	21 (53)
48 (122)	18 (45)	24 (60)
54 (137)	18 (45)	27 (68)
60 (150)	18 (45)	30 (75)

Note: Minimum Spacing “M” measured from outside diameters.



### 9.9.12 Steep Slope Installation

In applications where a steep slope (generally 20 to 30% or higher) is necessary, precaution should be taken to ensure that the application conditions will not adversely affect the pipe structure or flow characteristics. Important design considerations include the water hammer, the change of grade or direction thrust, and the drag-down forces due to the steep slope.

For any steep slope installation, the occurrence of water hammer or increased pressure at the joints, fittings, and grade changes is possible. One design consideration should be proper venting. The pipe must be properly vented to ensure negative pressure does not form inside the pipe. Venting can be provided along the pipe slope, at the head of the slope, or by designing the flow in the slope to not flow more than 75% full in peak design flow conditions. Providing ventilation through a manhole, access port or similar structure, will additionally help to maintain acceptable pressures in the system. Ideally, ventilation structures are designed at the top of the slope in order to more effectively minimize vacuum pressure.

Thrust blocks must be considered at all fittings and grade changes. With increased fluid velocity and abrupt changes in flow direction, restraints and thrust blocks are recommended at every fitting and grade change in order to prevent exerting excessive forces at that location. Thrust block location and design is generally the responsibility of the design engineer.

The pipe and the surrounding soil tend to move downhill on steep slopes. Pipe slippage can result in slope failure of the surrounding soil, structural damage of the pipe wall, or compromised of joint quality for the overall system. The pipe should be restrained through the use of concrete blocks or pipe anchors. Concrete anchor blocks should be cast around the pipe using notches in the undisturbed soil at intervals; in order to support the weight of the pipe between anchors. An investigation into the bearing capacity of the native material is useful. Figure 9.28 illustrates a typical project detail for an anchor block. The corrugations on the exterior of CPP provide an excellent mechanical lock, as compared to pipe types with smooth exteriors, and corrugations also assist when concrete anchors are poured. The dimensions of the concrete anchor are highly dependent upon the slope of the installation, the velocity of the water and the stability of the in-situ soil. Therefore it is most effective for the anchor system to be designed for the specific site conditions.

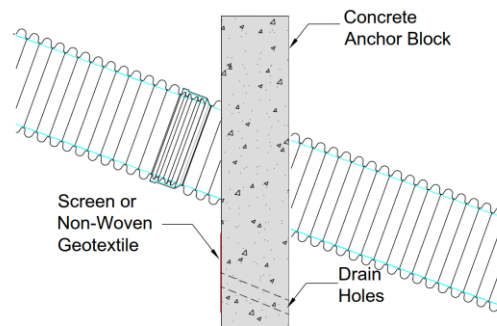

**Figure 9.28: Typical Concrete Anchor Block on Steep Slopes**

The pipe trench may act as a conduit for water to flow along the pipe and pipe trench and to build up pressure behind the anchors. Therefore, it is recommended that the anchor design include drain holes in the anchor blocks such that groundwater does not dam up behind them. There should be screens or non-woven geotextile fabric placed on the uphill opening of the drain hole in order to prevent a blockage.

For systems where fluid exits the pipe freely, the occurrence of wash out at that location is expected. Scour control measures should be implemented to avoid gradual erosion of the area. Splash blocks, rip-rap, or geotextile are just a few of the options available to prevent scouring at the outlet of the pipe. Anchoring of the pipe where the outlet end of the pipe is expected to be partially submerged is recommended to avoid the possibility of flotation. Methods similar to those discussed for anchoring joints are also applicable to anti-flotation designs.

### **9.9.13 Vertical installations**

CPP fittings, and reducers are sometimes installed in vertical applications, such as for use as catch basins and manholes risers. Adhering to installation requirements is important for vertical installations. Backfill material and compaction levels will determine the performance of the finished installation. Backfill shall extend a minimum of 1 ft (0.3 m) completely around the vertical structure for 8 to 24 in. (20 to 60 cm) and 18 in. (45 cm) for pipes with a 30 in. (76 cm) diameter and larger. Only Class I or II backfill material is recommended and should be compacted to a minimum of 90% compaction density. Flowable fill might also be an acceptable backfill material around vertical CPP installations.

Additional limitations on vertical installations include the following:

- Height of the vertical structure must not exceed 8 ft (2.4 m), unless the design is reviewed by the manufacturer or a qualified engineer;
- If traffic will be driving over a vertical structure, a concrete collar or similar structure (Figure 9.29) designed to transmit the load into the ground must be used. Traffic loads must not be transmitted directly into the pipe wall;
- Cast iron frames holding grates or lids must be seated on a concrete collar or similar structure such that the weight of the frame and grate or lid is transferred into the ground, and not onto the vertical pipe;
- Vertical installations in dams and spillways are generally not recommended and any design in these applications should be reviewed by the manufacturer or qualified engineer; and,
- Vertical installations of tees, elbows, and reducers, or any combination thereof, are subjected to the same limitations as previously described.

Additionally, vertical installations have a potential for flotation especially in areas of high groundwater. Typically, the vertically-installed fitting or pipe has an open bottom that is cast-in-place in a concrete base. The concrete base is designed such that the base's diameter is larger than the vertical structure. This base's diameter should provide sufficient surface area to hold down the vertical structure with the soil load resting on the base. The base thickness should also be designed to handle the shear and bending loads associated with buoyant forces. It is advisable to contact the manufacturer or a qualified engineer before designing a CPP in vertical applications.

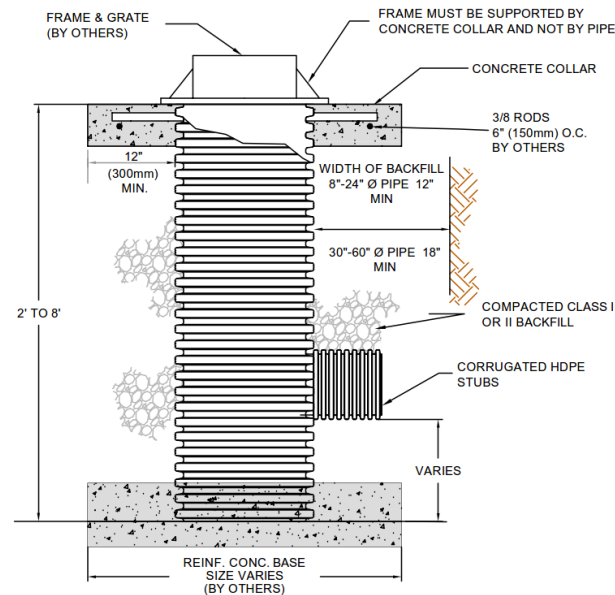

**Figure 9.29: Typical Vertical Installation Detail**

Vertical pipe installations are subjected to different loading conditions than the typical horizontal pipe installation, due to the difference in the pipe/soil interaction. The soil surrounding a vertical pipe locks into the corrugations, creating a drag down force as soil consolidation occurs over time. This drag down force may cause slight vertical movement of the corrugations that may lead to rippling of the interior liner. Rippling generally does not affect the performance of the finished installation and should not be a concern. Because vertical installations generally rise to the ground surface, they can pose safety concerns for people, vehicles, and animals. Vertical structures must be carefully designed and securely covered at all times in order to prevent injury or even death.

## 9.10 Post Installation Inspection

Construction and installation control includes a wide variety of quality control criteria including, but not limited to: pipe damage; grade and alignment; barrel condition (deflection or localized pipe wall bulges or dips in the pipe invert); and, joint assembly.

It is good practice to monitor deflection in the pipe during the installation process in order to ensure the allowable project deflection levels are not exceeded. It is especially important to check deflection levels in the beginning of the project to check that the construction procedure is adequate. One of the benefits of CPP is that it provides a quick indication of construction workmanship in the early stages of construction, which allows for modifications in the construction procedure before significant quantities of pipe have been installed improperly.

Under normal conditions, approximately 90% of the total deflection that is expected to occur over the life of project will occur within the first 30 days for compacted Class I and select Class II materials (i.e., GW and GP materials which were defined in Table 9.3). For this reason, the pipe is often checked for deflection 30 to 60 days after installation.

A practical and effective way to monitor the installation is through a visual inspection. Because of the highly reflective nature of CPP, lamping the pipeline with a high intensity light source from manhole to manhole will often show signs of localized deflection, flat spots, changes in curvature, bulges, localized dips in the invert and/or pipe deflection.

### 9.10.1 Deflection Limits

Deflection testing is generally not necessary when using proper construction practices associated with initial backfill material selection, placement, and compaction. However, some projects may require post installation deflection testing as a means of installation quality control. This is typically accomplished using a mandrel, laser measurement tools, direct measurement, or video inspection. Typically, deflection testing of 10% of the total length of the pipeline, or between two structures, whichever is greater, provides a reasonable indication of installation quality. The remainder of the system may be visually inspected by lamping the pipeline between manholes or structures.

The CPP industry recommends a conservative maximum deflection of 7.5% of the base inside diameter as measured within 30 days of installation, provided that the various design criteria associated with pipe strain are met. The base ID takes into account the variables inherent in pipe manufacturing processes such as inside diameter tolerances and out-of-roundness. The base ID is derived by subtracting the tolerance package from the pipe's statistical average ID. The tolerance package analysis is defined in Eqn. 9.2.

$$\textit{Tolerance Package} = \sqrt{A^2 + B^2} \quad (\text{Eqn. 9.2})$$

where:

- A = ID Tolerance;
- = 1.0% of pipe's statistical average ID;
- = 0.01\*ID, in. (cm);
- B = Out of Roundness Tolerance;
- = 3.0% of pipe's statistical average ID;
- = 0.03\*ID, in. (cm); and,
- ID = Statistical Average Inside Diameter provided by the pipe manufacturer, in. (cm).

ID Tolerance is based on the requirements in ASTM F 2306 (6). Out-of-roundness tolerances are consistent with the CPP product. The ID of CPP may have a rather large range of ID from manufacturer to manufacturer. This large range is a result of the AASHTO's attempt to convert the highway system to metric. The current requirement for ID tolerances in terms of oversized and undersized is provided in AASHTO (7). For example, a pipe with a 24 in. (60 cm) nominal ID may have a minimum ID of 23.64 in. (60 cm) or a maximum ID of 25.08 in. (63 cm). Therefore, it is important to use the pipe manufacturer's statistical actual average ID when analyzing for deflection.

Table 9.12 is developed for illustrative purposes to show the allowable vertical inside pipe height at 7.5% deflection. The tolerance package is derived from Eqn. 9.2. For the development of Table 9.12, the statistical average ID is assumed to be the nominal ID. The statistical average ID is typically taken from the manufacturer's quality control data.

This maximum allowable deflection is well within the structural limits of the pipe and provides an adequate factor of safety against reverse curvature, which would not be expected until the deflection is greater than 20%. Pipelines with large deflections should be analyzed before making the decision to remove and replace and a pipe manufacturer or a qualified engineer should be consulted for further analysis.

Some project requirements limit the deflection to 5%. Table 9.13 is developed to illustrate the allowable vertical deflection at 5% deflection. In Table 9.13, the statistical average ID is assumed to be the nominal ID.

**Table 9.12: 7.5% Deflection Dimensions for Base Diameter <sup>(1)</sup>**

Nominal Diameter in. (cm)	Tolerance Package in. (cm)	Base I.D. in. (cm)	Vertical Inside Pipe Height w/ 7.5% Deflection, in. (cm)
4 (10)	0.13 (0.33)	3.87 (9.83)	3.58 (9.09)
6 (15)	0.19 (0.48)	5.81 (14.75)	5.37 (13.64)
8 (20)	0.25 (0.63)	7.75 (19.68)	7.17 (18.21)
10 (25)	0.32 (0.81)	9.68 (24.58)	8.96 (22.75)
12 (30)	0.38 (0.96)	11.62 (29.51)	10.75 (27.30)
15 (38)	0.47 (1.19)	14.53 (36.90)	13.44 (34.14)
18 (45)	0.57 (1.44)	17.43 (44.27)	16.12 (40.94)
24 (60)	0.76 (1.93)	23.24 (59.02)	21.50 (54.61)
30 (75)	0.95 (2.41)	29.05 (73.78)	26.87 (68.25)
36 (91)	1.14 (2.89)	34.86 (88.54)	32.25 (81.91)
42 (106)	1.33 (2.38)	40.67 (103.30)	37.62 (95.55)
48 (122)	1.52 (2.86)	46.48 (118.06)	43.00 (109.22)
54 (137)	1.71 (4.34)	52.29 (132.81)	48.37 (122.86)
60 (150)	1.90 (4.83)	58.10 (147.57)	53.74 (136.50)

Note: (1) 7.5% allowable deflection provided all other design criteria are satisfied. Deflection calculations are based on nominal diameter; actual inside diameters may differ.

**Table 9.13: 5% Deflection Dimensions for Base Diameter <sup>(1)</sup>**

Nominal Diameter in. (cm)	Tolerance Package in. (cm)	Base I.D. in. (cm)	Vertical Inside Pipe Height w/ 5% Deflection in. (cm)
4 (10)	0.13 (0.33)	3.87 (9.83)	3.68 (9.34)
6 (15)	0.19 (0.48)	5.81 (14.75)	5.52 (14.02)
8 (20)	0.25 (0.63)	7.75 (19.68)	7.36 (18.69)
10 (25)	0.32 (0.81)	9.68 (24.58)	9.20 (23.37)
12 (30)	0.38 (0.96)	11.62 (29.51)	11.04 (28.04)
15 (38)	0.47 (1.19)	14.53 (36.90)	13.80 (35.05)
18 (45)	0.57 (1.44)	17.43 (44.27)	16.56 (42.06)
24 (60)	0.76 (1.93)	23.24 (59.02)	22.08 (56.08)
30 (75)	0.95 (2.41)	29.05 (73.78)	27.60 (70.10)
36 (91)	1.14 (2.89)	34.86 (88.54)	33.12 (84.12)
42 (106)	1.33 (2.38)	40.67 (103.30)	38.64 (98.14)
48 (122)	1.52 (2.86)	46.48 (118.06)	44.16 (112.16)
54 (137)	1.71 (4.34)	52.29 (132.81)	49.68 (126.18)
60 (150)	1.90 (4.83)	58.10 (147.57)	55.20 (140.20)

Note (1): 5% allowable deflection provided all other design criteria are satisfied. Deflection calculations are based on nominal diameter; actual inside diameters may differ.

### 9.10.2 Mandrel Test Devices

Mandrels are devices that are pulled through the pipe to determine whether the level of deflection is acceptable. A mandrel like that shown in Figure 9.30 is pre-set with the minimum allowable ID. If the mandrel can be pulled through the pipe, deflection is considered acceptable.

A limitation with mandrel testing is that the mandrel is a simple “go/no-go” device that might not pass through the pipe for a variety of reasons that are unrelated to deflection. A pipe with some debris in the bottom, a fitting that protrudes slightly into the pipe interior, or slight misalignment at the joint can all cause a mandrel test to report a failure, even if the amount of deflection is acceptable.

If it is thought to be necessary, any mandrel used should always have an odd number of fins. A mandrel with fewer fins (i.e., five instead of seven or nine) decreases the likelihood of catching debris or other interior protrusions that are not representative of actual pipe deflection.

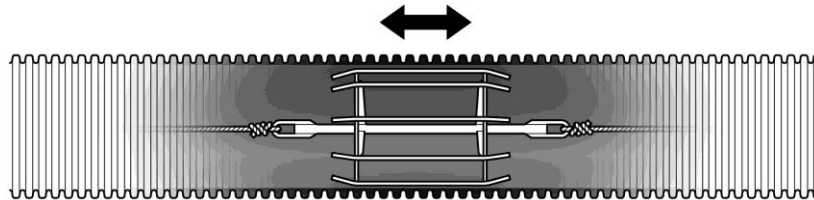

**Figure 9.30: Typical Mandrel**

### 9.10.3 Video Inspection

Remote inspection techniques such as closed-circuit television (CCTV) are often used in lieu of nonentry visual inspection. These remote inspection methods can be misleading regarding the condition of the interior of the pipe. It is particularly difficult to judge the size of defects in pipe using CCTV primarily because of lens distortion, and the fact that there are typically no references with which to scale the size of the defect. For this reason, it is recommended that an optically-corrected camera be used. Only qualified and trained personnel should conduct evaluation of the images from CCTV.

A laser profilometer is a technology developed for process piping inspection that has been occasionally used to inspect storm drainage pipe. This technology measures the interior of the pipe using a calibrated laser that casts a ring of light on the inner pipe wall; a camera; and, a mathematical algorithm to take measurements. Due to concerns with the reflective qualities of CPP, the presence of water, and other unique characteristics associated with CPP (e.g., slight waviness in the interior wall (pipe liner)), the Plastics Pipe Institute has not endorsed the use of these devices.

### 9.10.4 Joint Inspection

CPP pipe is intended for gravity flow drainage applications. Soil tight joints are often acceptable for gravity flow applications, but watertight joints may be needed and/or specified. When watertight joints are required to have joint tightness evaluations, the testing should follow the guidance presented in this handbook. It is important to note that the testing procedures for CPP pipe are no different than those for other gravity flow drainage products currently being used in the market.



Joint testing can be an important part of any watertight gravity drainage system, both in testing for infiltration and exfiltration. Infiltration tests are often used to estimate the amount of sewer water that will be conveyed to, and ultimately treated by, a wastewater treatment plant. Exfiltration tests are used to estimate the loss of sewage water into the surrounding soil. The two primary ways of testing sewer pipe joints for infiltration and/or exfiltration are using air or water to create a constant pressure within the system.

Valuable information can be gleaned by visually inspecting joints that have been assembled. The gap around the joint can be inspected. When a joint is properly aligned, the gap between pipe barrels will remain fairly consistent around the circumference of the joint. Variations in the joint gap, where the gap on one side is larger than the gap on the opposite side, may be an indication that the joint is askew.

Although it is the goal during joint assembly to install each joint fully without leaving any joint gap, this is not always possible, or desired (due to the potential of over-insertion), or even necessary. Bell and spigot joints with a rubber gasket provide a small range of positioning where the gasket is fully compressed to the desired amount within the joint assembly. Most CPP pipe manufacturers supply pipe with a home mark, which is visible on the spigot a few corrugations before the end of the pipe. When a spigot is inserted to the home mark, the installer is assured that the gasket is fully seated within the joint assembly. When a spigot is positioned at or very near the home mark, there may still be a gap between the liners of the two adjoining pipes. This should not be a concern provided that the joint gap is not excessive. The amount of joint gap that can be allowed, while still maintaining the desired joint integrity, varies by pipe diameter and by pipe manufacturer. For example, the maximum allowable joint gap can be 0.75 in. (1.9 cm) for CPP with pipe diameters of 12 to 30 in. (30 to 76 cm). For pipe diameters greater than 30 in. (76 cm), the maximum allowable joint gap permitted is 1 in. (2.5 cm). A pipe that has excessive joint gap can be pushed home, removed and re-inserted, or replaced until an acceptable gap tolerance is achieved.

If an indicator line such as a home mark, is not present, the pipe can be inspected from the inside in order to determine the amount of joint gap. In addition, a feeler gauge can be used to identify whether the gasket is consistently seated around the circumference of the spigot. These two steps of visual inspection are appropriate for inspecting the joints of any pipe material utilizing a bell and spigot assembly.

### **9.10.5 Hydrostatic Testing**

The testing gravity sewer joints via water infiltration or exfiltration is a common practice. For CPP, this testing should be conducted in accordance with ASTM F2487 *Standard Practice for Infiltration and Exfiltration Acceptance Testing of Installed Corrugated High-Density Polyethylene Pipelines* (2006). These standards require observation of the groundwater conditions and, if applicable, measurement of the infiltration rate of the groundwater through the joints. If groundwater is not applicable, then the line is filled with water and the leakage is observed through exfiltration. Manholes shall be tested separately and independently of the pipe line to the requirements established in the project specifications. When the water level is measured in the manhole for the exfiltration test, the leakage associated with the manhole shall be subtracted from the overall leakage of the test section in order to establish a pass or fail grade for the pipe.

The allowable leakage rate for corrugated HDPE is typically 200 gallons/inch-diameter/mile of pipe/day for both infiltration and exfiltration when tested in accordance with ASTM F2487 (2006).

### **9.10.6 Low Pressure Air Testing**

Air is a compressible gas and thus, it is extremely important to adhere to the appropriate safety regulations outlined in OSHA and project specifications. There are two primary national testing standards that may be applied to joint testing CPP: (1) ASTM F1417 *Standard Test Method for Installation Acceptance of Plastic Gravity Sewer Lines Using Low Pressure Air* (2005), and (2) ASTM F3058 *Preliminary Field Testing of Thermoplastic Pipe Joints for Gravity Flow (Non-Pressure) Sewer Lines* (2016). When either standard is specified by the project plans, it is important to review the standards carefully and to follow the testing procedure and safety precautions outlined.

ASTM F1417 (2005) entails testing a run of pipe from one manhole to the next adjacent manhole. Inflatable plugs are positioned into the manholes and secured. Air is introduced into the pipe line and gradually builds pressure. Once the line has been pressurized and is stable at 4 psi (27 kPa), the pressure is decreased to 3.5 psi (24 kPa) and at which time the line must not lose more than 0.5 or 1.0 psi (3.4 or 6.9 kPa), whichever is specified by the design engineer, in the specified amount of time. Table 9.14 summarizes the minimum time that must be reached for less than 0.5 or 1.0 psi (3.4 or 6.9 kPa) of pressure drop, depending on the diameter and length of the pipe being tested.

**Table 9.14:**

**Time to Pressure Drop for HDPE (per ASTM F1417)**

Pipe Diameter	Pressure Drop (psi)	Minimum Test Time (min:sec)	Length for Minimum Time, (ft)	Time for Longer Lengths, (sec)	Time for Length Shown, (min:sec)							
					100 ft	150 ft	200 ft	250 ft	300 ft	350 ft	400 ft	450 ft
12	0.5	5:40	199	1.709 L	5:40	5:40	5:42	7:08	8:33	9:58	11:24	12:50
	1.0	11:20		3.418 L	11:20	11:20	11:24	14:15	17:05	19:56	22:47	25:38
15	0.5	7:05	159	2.671 L	7:05	7:05	8:54	11:08	13:21	15:35	17:48	20:02
	1.0	14:10		5.342 L	14:10	14:10	17:48	22:15	26:42	31:09	35:36	40:04
18	0.5	8:30	133	3.846 L	8:30	9:37	12:49	16:01	19:14	22:26	25:38	28:51
	1.0	17:00		7.692 L	17:00	19:13	25:38	32:03	38:27	44:52	51:16	57:41
24	0.5	11:20	99	6.837 L	11:24	17:57	22:48	28:30	34:11	39:53	45:35	51:17
	1.0	22:40		13.764 L	22:47	34:11	43:34	56:58	68:22	79:46	91:10	102:33
30	0.5	14:10	80	10.683 L	17:48	26:43	35:37	44:31	53:25	62:19	71:13	80:07
	1.0	28:20		21.366 L	35:37	53:25	71:13	89:02	106:50	124:38	142:26	160:15

Data taken from ASTM F 1417<sup>d</sup> and Uni-Bell, Uni-B-6-98<sup>b</sup>.  
 It may not be necessary to hold the test for the entire time period listed above when it is evident that the rate of air loss is zero or less than the allowable pressure drop and authorized by the approving authority<sup>1</sup>.

When the pipe is large enough to be physically accessed, it may be desirable to test individual joints for safety reasons. In these cases, joint testing in accordance with ASTM F3058 (2016) should be considered, which is also referred to as a joint isolation test. The PPI recommends a joint isolation test, in lieu of a full line test, for testing pipe diameters of 3 in. (91 cm) and larger for safety reasons. This test is typically done with air, though water may also be used, and involves the use of special testing equipment. The equipment consists of two inflatable bladders, placed on each side of the joint, which creates an open center cavity between them. The bladders are inflated and then the center cavity is pressurized to 3.5 psi (24 kPa). The joint passes the test if the pressure is held for 5 seconds without dropping more than 1.0 psi (6.9 kPa). For all practical purposes, this is a go/no-go test and the final acceptance of the pipeline per this testing method shall be at the discretion of the design engineer. One advantage of this type of test is the ability for the installer to quickly test the joint immediately after installation, which allows for any corrective measures to be taken early on in the project.

### 9.11 Safety and OSHA Precautions

Pipeline construction can be dangerous if appropriate precautions are not followed. Therefore, every effort must be taken to provide a safe working environment for workers installing CPP. Federal regulations that cover safety for construction are published in the Safety and Health Regulations for Construction under the Department of Labor, Occupational Safety and Health Administration (OSHA). One of the most common trench safety structures is the trench shield which is governed by the Occupational Safety and Health Administration (OSHA) 29 Code of Federal Regulations (CFR) Part 1926.650-.652 Subpart P-Excavations (2018). Because this handbook does not cover all of the possible construction site and trench safety requirements, it is advisable to review local, state and federal publications for the most current requirements.

## 9.12 References

1. **ASCE**. *Gravity Sanitary Sewer Design and Construction*. New York : American Society of Civil Engineers, 1982.
  2. **Moser, A. P.** *Buried Pipe Design*. Logan : McGraw Hill, 2008.
  3. **AASHTO**. *AASHTO LRFD Bridge Design Specifications, Section 12*. Washington D.C. : American Association of State Highway Transportation Officials, 2012.
  4. *OSHA Fact Sheet Trench and Excavation Safety*. **OSHA**. Washington D.C. : OSHA, Vols. OSHA 3267-09N-05, 2018.
  6. **Howard, Amster**. *Native Flowable Fill Investigatio for the IPL*. Dallas : Proceedings ASCE Conferance Pipelines, 2013.
  7. —. *Flowable Fill and the RBIC Pipeline*. Atlanta : Proceeding ASCE Conferance Pile Line, 2008.
  8. ASTM D2321 Standard Practice for Underground Installation of Thermoplastic Pipe for Sewers and Other Gravity-Flow Applications. **D2321, ASTM**. West Conshohocken, 2011.
  9. **Howard, Amster**. *Sustainable Flowable Fill*. Miami Beach : Proceedings ASCE Conferance Pipelines, 2012.
  10. —. *Pipeline Installation*. Lakewood : Relatively Publishing, 1996. First Edition.
- ASTM F1417, Standard Test Method for Installation Acceptance of Plastic Gravity Sewer Lines Using LowPressure Air, ASTM, 2005
- ASTM F3058, Preliminary Field Testing of Thermoplastic Pipe Joints for Gravity Flow (non-Pressure) Sewer Lines, ASTM, 2016.
- Uni-B-6-98, Recommended Practice for Low-Pressure Air Testing of Installed Sewer Pipe, Uni-Bell PVC Pipe Association, 1998
- ASTM F2487, Standard Practice for Infiltration and Exfiltration Acceptance Testing of Installed Corrugated High Density Polyethylene Pipelines, ASTM, 2006